

**MACHINE SHOP LAYOUT, INSTALLATION,
TOOLING, AND PERSONNEL TRAINING**

Keith G. Benedict

Submitted to the Graduate Faculty
in partial fulfillment of the requirements
of the degree
Master of Science in Industrial Management
University of Southern Indiana

July 1999

Acceptance

Accepted by the Graduate Faculty, University of Southern Indiana,
in partial fulfillment of the requirements of the degree of
Master of Science in Industrial Management.

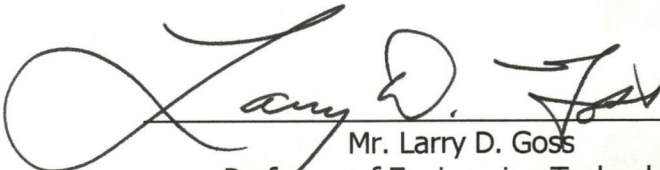

Mr. Larry D. Goss
Professor of Engineering Technology



Mr. Augustine J. Fredrich
Professor of Civil Engineering Technology

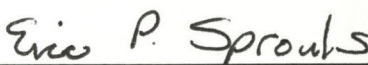

Mr. Eric Sprouls
Associate Professor of Engineering Technology



Mr. Curtis Hooper
Maintenance Engineer - Lexan Finishing

Dedication

To shop teachers everywhere who have learned how-to-do,

and now share their knowledge to show others how, too;

Who have gotten their hands dirty while practicing their craft,

with a vigor that to those-who-can't may seem a little daft;

Flying chips and spinning tools, cutting iron and turning steel,

never building ivory towers, knowing what is real.

This is for you...

Acknowledgements

The author gratefully acknowledges the following individuals for their help not only with this project but also with assisting the author get to the point in life that would make this project possible.

Many thanks to Professor Larry D. Goss, my project advisor, colleague, and good friend. He has *been there and done that* and knows what is real.

Thanks also to Jay, Eric, Len, and Jack, who have not only shared their knowledge as professors and their advice as colleagues but can also be counted among the author's friends.

A large measure of thanks to the author's wife and son, for putting up with the author's absence, preoccupation, and moodiness while giving full support throughout this project.

And a final measure of thanks to the author's father, Keith J. Benedict, the only machine shop manager to ever receive a retirement plaque from the United Steel Workers of America union members he supervised for over twenty-five years. It bears the following inscription: *The Best Supervisor Bucyrus-Erie Ever Had*. Having worked as a machinist in his area for several years, the author learned first-hand the virtue of hard work and honest treatment of people, and concurs wholeheartedly with the sentiments expressed on the plaque.

Abstract

Benedict, Keith G. MSIM, University of Southern Indiana, July 1999. Machine shop layout, installation, tooling, and personnel training. Major Professor: Larry D. Goss.

General Electric Company's Mt. Vernon operation employs a number of technicians to maintain its plastic fabricating equipment. Maintenance engineers in charge of several functional areas want these technicians to perform simple machining operations to reduce the cost and time associated with the current practice of outsourcing machine work.

The author was retained as a consultant to set up a machine shop, specify and order tooling, develop a customized training program for the technicians, and teach machining skills to several groups of students.

These tasks have been accomplished, with the training materials organized as a website, allowing them to be easily modified and accessed with any Web browser from a computer disk, an intranet, or the Internet.

Table of Contents

Topic	Page
Part I: Introduction	
Introduction.....	1
Initial Scope of Project.....	1
Organizational Structure.....	2
Tooling, Shop Layout, and Equipment Installation.....	3
Additional Concerns.....	4
The Scope of the Project Expands.....	5
Establishing Training Schedules.....	5
Part II: Machine Shop Layout and Equipment Installation	
Factors Influencing the Design.....	7
Technical Features of the Approved Layout.....	9
Installation of the Lathe and Milling Machine.....	10
Unresolved Problems/Unfinished Business.....	13
Part III: Tooling the Shop	
Categorization of Tooling Needs.....	16
Measuring Tools.....	17
Lathe Setup Tools.....	19
Lathe Cutting Tools.....	20
Milling Machine Setup Tools.....	21
Milling Machine Cutting Tools.....	22
General Purpose Cutting Tools.....	23

Part IV: Training and Skills Verification

Characteristics of a Maintenance Machinist's Job.....	24
What a Maintenance Machinist Should Know	24
Using Computer-Based Technology for Training.....	26
The Machinist's Assistant is Born.....	27
Software Features	27
The Proposed Training Sequence	28
Refresher-Training and Document Generation	29
Basic Training Course - Background	33
Observations and Educational Methodology.....	34
Educational Delivery and Document Generation	36
Skills Verification of Employees.....	37
Summary and Conclusions.....	39

Part V: Glossary

Glossary of Technical Terms.....	G1
----------------------------------	----

Part VI: Bibliography

Bibliography	B1
--------------------	----

Part VII: Appendix A - Correspondence and Illustrations

E-mail of 7/27/98.....	A1 - A3
E-mail of 8/11/98.....	A4
E-mail of 11/23/98	A5 - A7
E-mail of 11/24/98	A8
E-mail of 11/26/98	A9
Illustration #1: Milling Machine and Storage Racks	A10

Part VII: Appendix A - Correspondence and Illustrations (continued)

Illustration #2: Milling Machine and Storage Racks	A10
Illustration #3: Milling Machine and Storage Racks	A11
Illustration #4: Engine Lathe and Storage Racks	A11
Illustration #5: Original Room Layout.....	A12
Illustration #6: New Room Layout	A13
Illustration #7: Screw Adjuster and Machinery Leveling Pads	A14
Illustration #8: Wedge Type Machinery Leveling Pad	A14
Illustration #9: Cross Section of Floor Anchor and Leveling Screw	A15
Tool Order.....	A16
Illustration #10: Fixed and Adjustable Gauges	A17
Illustration #11: Combination Square Set	A17
Illustration #12: Several Common Precision Measuring Tools.....	A17
Illustration #13: Lathe Tailstock Centers	A18
Illustration #14: Typical Lathe Operations	A19
Illustration #15: Typical Negative Rake Lathe Tools and Carbide Insert	A20
Illustration #16: Typical Milling Machine Operations	A21
Illustration #17: Milling Machine Table T-Slots w/T-nut and Stud	A22
Illustration #18: Various R-8 Shank Tools.....	A23
Illustration #19: Other Tool Shank Styles	A23
Illustration #20: Opening Screen of MACHINIST'S ASSISTANT program.....	A24
Illustration #21: Main Page of Engine Lathe Section	A24

Part VIII: Appendix B - Lesson Plans & Student Handouts

Session: #1 Lesson Plan w/6 Handouts

Session: #2 Lesson Plan w/9 Handouts

Session: #3 Lesson Plan w/5 Handouts

Session: Lexan #4/CPP #4 & #5 Lesson Plan w/6 Handouts

Session: Lexan #5/CPP #6 Lesson Plan w/3 Handouts

Session: Lexan #6 & #7/CPP #7 & #8 Lesson Plan w/5 Handouts

Session: Lexan #8 & #9/CPP #9 Lesson Plan w/1 Handout

Session: #10 Lesson Plan w/0 Handouts

Part I: Introduction

Introduction

This project began in the middle of July 1997. Mr. Curtis Hooper, Maintenance Engineer at the General Electric (GE) Lexan® Finishing operation in Mt. Vernon, Indiana, has implemented many changes in the maintenance area including upgraded preventive maintenance procedures and improved training of employees. One of his current efforts is focused on the lost time associated with outsourcing machine work on damaged or specially modified parts for their production equipment.

Mr. Hooper wanted to know if the author would be interested in setting up a small machine shop and in developing and delivering training in machine shop operations for some maintenance employees in the GE Lexan® plant. After some preliminary discussions, an exchange of e-mails (see Appendix A pg. 1-4), and an on-site visit to see a room dedicated to become a machine shop, the author agreed to perform the following four services:

Initial Scope of Project

1. Lay out the shop, showing the locations of a vertical milling machine, surface grinder, and engine lathe, including the preparation of documentation needed for millwrights to install the equipment.
2. Provide a final check of the location, leveling, and anchoring of the three pieces of equipment within the shop.
3. Determine the type of setup, measuring, and cutting tools needed to perform common machining and measuring operations. Provide all information necessary to order these tools.
4. Develop a training and skills verification program for the personnel who will use the machine shop, and teach the first group of students.

The individual technical features of each of the four activities are unremarkable. Machine shop layout, equipment installation, and apprentice training have been performed for more than a hundred years. Tooling for machine tools is widely available through numerous vendors, although it is extremely varied and can be highly specialized. The project required the management of these activities in the most efficient way to minimize time and cost.

Based on the activities mentioned above, the following four goals were established:

1. Any shop layout should provide a safe working environment, allow for maximum versatility in the use of the equipment, and permit growth should additional equipment be acquired.
2. Equipment should be installed and leveled to professional standards, so that accurate work can be safely performed.
3. All tooling recommended for purchase should be of good quality, capable of performing a wide variety of functions. Cutting tools should be versatile and sized to match the machines they will be used on.
4. Student training should concentrate on the basic skills needed to set up workpieces and safely perform common machine operations. Use of measuring tools and basic shop math should be emphasized. The use of modern technology and computer-based training methods should be utilized where possible.

Organizational Structure

GE's Mt. Vernon plant has a rather unique organizational structure. General Electric owns the physical facility, which is divided into several operations, one of which is the Lexan® Finishing operation. Each of these operations is semi-autonomous and manages its own production and maintenance employees. These maintenance employees are responsible for most preventive and emergency maintenance tasks and are the target group for machinist training.

Another company, Fluor-Daniels Inc., is responsible for managing new construction and equipment installation. This function is fulfilled by keeping several union millwrights onsite and by hiring additional manpower as needed by contracting with Industrial Contractors, Inc. (ICI). The author had to interact with these two organizations to arrange for moving, installing, leveling, and anchoring the equipment in the machine shop.

Tooling, Shop Layout, and Equipment Installation

The first two activities that needed to be performed were the ordering of tooling and the determination and documentation of an acceptable layout for the machine shop. There can be a significant time lag involved in ordering and receiving tooling, and the millwrights who would perform the equipment installation required documentation to begin their work. The activity of leveling and verifying the equipment installation would take place after the millwrights were finished.

On Friday 21 November 1997 the author, having acquired all the necessary safety equipment, training and clearances, met with Mr. Hooper and began the task of measuring the machinery and the machine shop. This room, which measures thirty six-feet eight-inches by twenty four-feet eight-inches with a sixteen-foot ceiling, has a poured concrete floor, cement block walls, and a flat metal roof supported by lightweight prefabricated steel beams. One wall was to have a doorway cut through to an adjoining room. The concrete floor was thick enough to support the metal-working equipment but too thin to safely anchor a jib crane, and the ceiling beams were too light to be used to hang an overhead crane.

An initial draft of the machine shop layout and a list of the necessary tools was compiled. After an exchange of e-mails (Appendix A pg. 5 - 9) several meetings were held in which the basic plans were approved by Mr. Hooper.

Purchasing Coordinator Don Mann, the individual who would be responsible for placing the tooling order, was given the list of tools. The final drawings showing the layout of the machine shop were presented to Site Manager Terry Mansfield of Fluor-Daniels and Project Manager Jim Edwards of ICI.

Various methods of leveling and anchoring the engine lathe, milling machine, and surface grinder were discussed. An engine lathe has a long base that needs to be evenly supported and accurately aligned. Any twist or uneven support can degrade a lathe's accuracy. Mr. Mansfield and Mr. Edwards had experience in mounting and anchoring different types of equipment. The minimum strength and mounting accuracy standards for each piece of equipment were explained. An agreement on the exact method of mounting each piece of equipment was reached.

The millwrights completed the installation on 7 January 1998. On Friday, 8 January 1998, the author and a GE millwright finished leveling and securing the lathe and milling machine. The author also used this time to complete another activity by taking digital photographs of all the equipment, which would be used later as part of the training materials.

Additional Concerns

The machine shop was originally a maintenance storage room. As can be seen from the pictures and plan view drawing (Appendix A pg. 10 - 12), the walls of the room are lined with heavy-duty pallet storage racks from floor to ceiling. This prevented the surface grinder from being relocated and anchored. The author had expressed concern about relocating this particular piece of equipment, since it was GE's responsibility to move the racks. All the parties involved agreed that cost and time associated with moving this machine at a later date would be covered by a separate contract.

In order to have a safe and efficient machine shop, parts and raw materials must be moved in, worked on, stored, and moved out. Material storage racks and workbenches suitable for the type of work performed in a machine shop could be easily purchased or fabricated and were dismissed from immediate concern. Several methods of material handling, such as the use of a forklift and/or the installation of some type of crane were discussed with Mr. Hooper, Mr. Mansfield, and Mr. Edwards. It was agreed that this problem would be dealt with after the shop was in regular use and that the final resolution was GE's responsibility.

The Scope of the Project Expands

Mr. Steve Gries, Reliability Engineer for GE's Crystalline Polymer Products (CPP) – Maintenance area, had heard about the upcoming machinist training in the Lexan® shop and wanted to discuss the possibility of having his maintenance technicians receive similar training. The CPP area, which produces Valox, is another semi-autonomous operation at the Mt. Vernon plant .

After several discussions, an on-site meeting was held with Mr. Gries. The CPP machine shop contained a vertical milling machine and an engine lathe. The author agreed to expand the scope of the project by training the CPP maintenance employees on these two machines using the same basic material that would be used for training the Lexan® maintenance employees.

This opportunity was used to take digital photographs of the machine tools in the CPP shop, which would be included in the training materials used to train the employees in this area.

Establishing Training Schedules

During discussions with Mr. Hooper and Mr. Gries, it was determined that both areas had employees who had received machine shop training elsewhere. Mr. Hooper and Mr. Gries wanted to have several refresher-training sessions for these employees.

This would enable the author to get to know the employees in both areas and to become better acquainted with the specific equipment in both shops. Training for the inexperienced employees would follow. With this determined, the activities of planning a training sequence and developing the training material could begin.

Part II: Machine Shop Layout and Equipment Installation

Factors Influencing the Design

Machine shop design and layout falls under the general category of facilities planning. Some of the factors that enter into the problem are quantifiable; others are not. A satisfactory solution is more often a matter of good judgment than rigorous mathematical analysis.

Some of the factors that needed to be considered for this particular case included:

1. The shape and size of the space allocated for the machine shop.
2. The quantity, type, size, function, and ergonomics of the machinery that would eventually be installed in the shop.
3. The availability and location of utilities such as electricity and compressed air.
4. The size, type, and quantity of work that would be performed.
5. Any outside circumstances that would impact the use of the machine shop.
6. The level of investment GE was willing to make in setting up this room as a machine shop.

Mr. Hooper had received the necessary management approvals to convert a storeroom in an outbuilding to a machine shop. Thus the size and shape of the room was fixed. Measurements were taken of the room during an onsite visit. A CADKEY® drawing was generated from this data and stored for future use.

A new lathe, a vertical milling machine, and a surface grinder were the only items on the original list of machine tools that were to be in the shop. Mr. Hooper agreed that leaving room for another tool such as a heavy-duty cut-off saw, drill press, or horizontal mill might be a good idea. The lathe, milling machine, and surface grinder were available for measurement.

The size, shape, and location of these items, as well as every other major item in the room, was added to the previously generated CADKEY® file. Specifications including capacities and power requirements were determined from inspecting the equipment and reading the equipment manufacturer's documentation.

Utilities were not a problem. Adequate electrical power and compressed air were both available. It was made clear that GE would arrange for any electrical or mechanical work that was required and that this was not the author's responsibility.

This was to be a maintenance machine shop and not a production facility. While this would require a maximum amount of flexibility in the type of operations that could be performed, it would also restrict the work to the type of hardware items used in plastic fabrication. It was made clear that the current practice of contracting out machine work on pieces that were too large, too specialized, had too close a tolerance on certain features, or would be too time consuming to work on in-house would have to continue.

As is typical of any thermoplastic fabrication facility, GE uses screw-type extruders to compound and form its product. These items have several long, slender parts that can become rough, worn, or damaged and may require repair. There are many innovative ways to extend the capacity of lathes and milling machines to enable them to handle parts that are longer than the machine's stated specifications would seem to indicate. Adjustable-height roller stands can be used to support work that extends off the end of a milling machine table. Depending on the part geometry, a steady rest can be used to allow a lathe to turn a shaft approximately twice as long as the specified center distance at slow speeds. This would allow a ten- to twelve-foot long extruder barrel or screw to be honed or polished on a lathe with a six-foot bed. Lathes also have hollow spindles, so that bar stock can be fed through from the headstock end of the machine.

Maximum end access to the lathe and milling machine was considered a desirable feature of an acceptable machine shop layout.

One wall of the new machine shop was common to a room that would be turned into a precision pump repair shop. The location where an opening was to be cut into the common wall for a metal door was pointed out. This door only needed to be wide enough for people to use, as parts could be moved from shop to shop via a forklift through the overhead doors. The door would be located near the front wall, as close to it as practical, to leave the maximum amount of useable space along the common wall.

It was made clear that GE considered the economics of this project to be proprietary information and not within the author's purview. It should be noted that GE has already made a substantial investment in machinery, tooling and contract labor, and has made a firm commitment to train the maintenance technicians to use this resource effectively.

Technical Features of the Approved Shop Layout

The drawing of the approved layout is included as page 13 of Appendix A. The lathe and milling machine are turned at an angle relative to the walls of the room. In the case of the lathe, the main axis of the spindle points out the front door, clearing the right-hand doorframe by approximately eight inches. This increases the distance from the left end of the tailstock to the wall by an amount sufficient to allow a twenty-foot piece of bar stock to be fed through the spindle. This was thought to be a desirable feature, since most machinable materials are available in standard twenty-foot lengths.

In the case of the milling machine, the distance from the spindle to either wall, when measured parallel to the long axis of the table, is large enough to permit working on one end of a twenty-foot piece of bar stock while the other end is supported by one or more roller stands.

A further benefit of angling the machines in the fashion shown is increased operator safety when both the milling machine and the lathe are in use at the same time. Should a piece come out of the lathe, the most likely trajectory would be to the left side of the milling machine operator. If the machines were parallel to each other, the operators would have their backs to each other, and any piece that might accidentally come loose from the lathe would be much more likely to strike the milling machine operator in the back.

The storage area along the east wall is long enough for storage of twenty-foot bar stock without interfering with passage through the proposed door into the pump shop.

The area immediately inside the overhead door is to be left open at this time. This will be used as a staging area for incoming, outgoing, and in-process work. At a later date some of this space may be used for a drill press, cut-off saw, or other machine tool.

An adequate amount of free space along the walls has been left unassigned. This area may be developed with work tables and storage racks to suit the work patterns of the employees and the type of workpieces they will be machining.

Installation of the Lathe and Milling Machine

The lathe is intended to be mounted and leveled by using the ten hollow screw adjusters located around the base of the machine (Appendix A pg. 14). Threaded studs are anchored into the floor and pass up through shim blocks and each of the leveling screws.

Shim blocks are needed to raise the lathe up high enough to permit machinery leveling pads to be used. The screw adjusters, which are threaded into the base of the lathe, can be turned to level the lathe. When the lathe is in the proper position, jam nuts are tightened to lock the screw adjusters into place. The bearing area of the end of the screw adjuster is inadequate to support the lathe adequately for long-term use, so additional support must be provided. In this instance, ten wedge-type machinery leveling pads were needed to provide firm support under the lathe bed (Appendix A pg. 14). The nuts on the threaded studs are then tightened evenly all around in several steps until a specified final torque value is reached.

The milling machine has four holes, one on each corner of the base, and no screw adjusters. The typical installation procedure for this type of machine is to anchor four threaded studs into the floor and use solid shims and a trial-and-error procedure to raise the low corners of the machine into a level attitude. Once leveled, the nuts on the threaded studs are tightened evenly to their specified final torque.

Another problem concerned the means of actually securing the threaded mounting studs into the concrete floor. Various types of concrete anchors are available, including lead anchor and expanding plug types. All of these require holes to be drilled into the concrete floor, and while this is not especially difficult with the proper tools, the aggregate used in most concrete can cause the holes to wander away from their desired location. Putting one hole in the right spot would be hard. Putting four holes in the right spots would be much more difficult, and locating ten holes accurately would be nearly impossible.

Mr. Mansfield and Mr. Edwards solved this problem by suggesting the use of a somewhat nontraditional method in which they have great confidence (Appendix A pg. 15). Instead of trying to align the holes perfectly, oversize holes are drilled as close to the proper position as possible.

These holes are then filled with one of the several grades of epoxy glue that are designed specifically for this purpose. The machines are then located over the holes, and threaded studs are inserted through the holes in the machine base down into the epoxy. The alignment is perfect, since the machine is the actual template. The epoxy binds tightly to the threads of the stud and to the concrete walls of the hole. One added benefit is the slight positive expansion of the epoxy as it cures; this locks the epoxy into the hole very tightly to prevent the stud from being pulled out. This method compares very favorably in strength with other types of anchoring methods, and is much easier and quicker to use while giving almost perfect results. It was agreed that this method would be used.

The lathe and milling machine were leveled as closely as possible by the union millwrights retained by ICI. At Mr. Hooper's request, the author and a GE maintenance employee performed the final leveling and tightening. The lathe was very close to level, requiring less than an hour to finish. All leveling was checked by using a machinist's bubble level with a precision of .0005 inch per foot. Leveling was concluded when no perceptible change in the bubble was noted after turning the level end-for-end at several places along the bedways. Readings were taken both parallel and perpendicular to the bedways.

There is nothing really magical about having a lathe bed be level in the horizontal plane. Many Computer Numerical Control (CNC) lathes have slant beds that are oriented neither horizontally nor vertically but are instead inclined at an angle. The main purpose in leveling a lathe to a known orientation is to eliminate any twist from the bedways, which can cause tapering and barreling of cylindrical workpieces.

The engine lathe was then tested. The mechanical controls worked perfectly, but the electrical connections seemed defective.

The electrical accessories such as the worklight and coolant pump worked, but the lathe spindle would only rotate in the reverse direction, which is seldom used. Ordinarily this would mean that the electrical connections to the spindle motor were reversed, so a work order was filled out to correct the situation.

The final leveling of the milling machine took somewhat longer to accomplish. The millwrights had used too many thin shims under the corners, raising the mill up higher than necessary and making the base "springy" as the shims compressed and flattened out. It was necessary to remove all the shims and start fresh. The highest corner was found and all the other corners were raised until level was achieved. The least number of shims necessary to achieve this condition was used. When leveling a milling machine of this type, the table surface is used as the horizontal reference plane. It is necessary to tighten the gib lock clamps that anchor the knee to the column and the saddle to the knee when doing this to take up all the slack in the system. This machine was leveled to the same specifications as the lathe, and the nuts were tightened to their specified final torque value. The level was rechecked and found satisfactory.

The milling machine was tested under power to ensure correct operation and to test the electrical connections. The spindle drive system operated correctly in all respects, but the power table feed attachment was defective; it would only operate when in the rapid traverse position. This unit was found defective and replaced with a new unit.

Unresolved Problems/Unfinished Business

A main concern was workpiece handling within the shop. It is expected that a forklift truck will be used to transport work to and from the machine shop area.

The lathe and milling machine are capable of handling workpieces that are larger and heavier than can be safely lifted and manipulated by a person. Several different means of workpiece handling were discussed, with three options identified:

1. Use a forklift truck equipped with chains, straps or other devices to lift the workpieces onto the machines.
2. Install a column and jib crane in a location that can service the lathe, milling machine, surface grinder, and staging area.
3. Install a elevated rail gantry crane that would cover the entire shop area, including storage racks along several walls.

Using a forklift truck is the lowest cost option, since an adequate number of forklift trucks are already available. This is the current method and should prove to be satisfactory for a while. There are several disadvantages to this, however. It is awkward; it requires two people to implement safely; and it limits further development of the shop because of the floor space required for access.

The cost and time required for the installation of a column and jib crane was estimated to be greater than the cost and time of installing a gantry crane. The column of a jib crane is essentially a cantilevered beam loaded under both compression and bending. The load exerted on the floor by the column requires a very firm foundation to be safely supported. The floor in the machine shop would have to be reinforced quite heavily in order to handle a crane with a long enough arm and sufficient capacity to be useful.

The cost of a jib crane is much lower than that of a gantry crane. Mr. Mansfield and Mr. Edwards thought there were several used gantry cranes stored on-site.

These cranes had been removed from other buildings during various remodeling projects. They believed that a suitable gantry crane could be found among these, and that the cost of reworking and installing one of these would be reasonable. Mr. Hooper agreed to put this item into the project's budget and to have a gantry crane installed at a later date.

One item of unfinished business is the surface grinder, which could not be anchored in place because of the storage racks lining the walls of the room. Until these racks are moved, this machine will remain in its original location (Appendix A pg. 12), which interferes somewhat with the use of the milling machine. It is hoped that this situation will change soon, but it is the responsibility of GE to correct this. Mr. Hooper agreed that training on this machine would not be part of the initial training program.

Another item of unfinished business involves the acquisition of worktables, storage racks, and tool boxes. Items such as worktables and storage racks could easily be built by the employees to suit their specific needs, while items such as toolboxes will probably need to be purchased.

Part III: Tooling the Shop

Categorization of Tooling Needs

The tooling required to equip the machine shop was placed into six general categories:

1. General measurement tools such as micrometers and scales.
2. Specialized hardware used to set up and secure parts to the lathe.
3. Cutting tools used primarily on the lathe.
4. Specialized hardware used to set up and secure parts to the milling machine.
5. Cutting tools used primarily on the milling machine.
6. Cutting tools useable on the lathe and milling machine.

Before a list of tools was generated, an inventory of the existing tooling was performed.

No measuring tools of any kind were available specifically for this shop, although many of the maintenance employees had vernier or dial calipers and micrometers in their personal toolboxes.

The only tooling available for the milling machine was a set of expanding collets (used to hold end mills into the spindle), a 1/2" capacity drill chuck, and a heavy-duty machinist's vise.

The lathe came with a number of accessories, including a three-jaw chuck, a four-jaw chuck, a roller-type steady rest, a follow rest, a lathe spindle center and a "dead" tailstock center, as well as a tool box with a minimal set of basic tools such as hex socket and open end wrenches.

Measuring Tools

The acquisition of good quality measuring instruments was considered a necessity. It has been the author's experience that good quality measuring instruments, if taken care of properly, will provide a lifetime of service. It is likely that most of the measuring tools in this machine shop will experience infrequent use and will have a long service life. It was decided that the initial measuring tool purchases should be of tools that would give the most versatility and were either dimensionless transfer instruments or were inch-based or inch/millimeter based. No SI-only (System International, the new form of the metric system) instruments were to be purchased, although this would be considered in the future. These tools were to be used in a maintenance shop, where the duplication of existing parts was considered to be the principal activity.

Production machinists work from detailed drawings with established tolerances on shape and size features to permit full interchangeability of all the resulting finished parts in an assembly. Having accurate tools graduated in the proper system of units is a necessity under these conditions. Maintenance machinists generally fit individual parts together by transferring the measurements of the original part to the new part being machined. The initial lack of millimeter-based measuring tools was not considered to be a problem in this context. The final list that was submitted and approved for purchase is included in this report (Appendix A pg. 16). Note also that illustrations of some of the tools mentioned here are also included (Appendix A pg. 17).

There are three broad categories of geometric features that require measurement: lengths, angles, and shapes. Length measurements include such features as inside and outside diameters of circular surfaces, depths and widths of grooves and slots, and distances from circular or plane surfaces to other circular or plane surfaces.

Angular measurements include features such as conical tapers on cylindrical workpieces and the intersection angles of plane surfaces with circular or plane surfaces on prismatic parts. Shape measurements include the gauging of the radii of fillets and rounds, and the shape of involute curves or other special shapes.

Dimensionless transfer instruments such as inside and outside spring calipers, telescoping and small hole gauges, and bevel protractors are used to transfer a dimension from a part to a measuring tool such as a steel scale or vernier protractor. Since these instruments are not graduated, they are equally useful with inch- and millimeter-based measuring tools. They are also used to establish the size of one part to use as a basis of comparison to a mating feature of another part. In fact, it is possible for a skilled machinist to fit parts together properly without ever establishing the numerical value of a single dimension by using this method.

Length measurement tools include steel scales, inside, outside, and depth micrometers, vernier and dial calipers. The steel scales were specified to have what is known as a "4R" set of graduations, with one of the four usable scale surfaces divided into 1/8" increments, the next into 1/16ths, followed by 1/32" and 1/64" divisions. This yields four levels of precision or resolution, and allows the machinist to use a coarsely divided scale for quick measurements and a finely divided scale for close measurements.

The micrometer movements used on the specified inside, outside, and depth micrometers are of the conventional pattern, with a resolution of .001". It was possible to save a significant amount of money by selecting sets of instruments that have one basic micrometer movement and replaceable stems or extensions. Since the tools will be used in a low-volume operation, it was judged to be advantageous to buy more tools with a greater flexibility as opposed to fewer tools of a more rugged and dedicated nature.

In every possible case, gauges or fixed standards used for calibration were ordered along with the micrometers. This will allow the accuracy of the instruments to be maintained during their useful life.

Angular measurements are read by using a protractor. The protractor head that comes with a combination square set is divided into 1° increments. The vernier protractor set is divided into $0^\circ-5'$ increments.

Shape measurement tools can cover a wide range of profiles and forms. The majority of such tools are fixed gauges. The tools specified for initial purchase included a set of inside and outside radius gauges used for checking fillets and rounds, a screw pitch gauge used to check thread pitch and profile, and a 60° center gauge used to check the depth of the tapered holes used for centering shafting on a lathe.

Other measuring tools were also included in the order. Since their functions are obvious they will not be discussed here.

There were a number of useful tools such as thread micrometers, adjustable parallel blocks, and vernier height gauges that were too expensive or too specialized to be included on the initial purchase list. It was decided that these and other measurement tools would be purchased later when a need becomes evident.

Lathe Setup Tools

The engine lathe came with most of the major hardware accessories needed to secure workpieces for machining. As is typical with package deals of this type, neither a faceplate nor any dogs, which are used when shafting is turned between centers, were included.

A "dead" (nonrotating) High Speed Steel (HSS) tailstock center was included, but it has been the author's experience that such centers do not last very long if inadequately lubricated. It was decided that a "live" (rotating ball bearing) tailstock center should be purchased (Appendix A pg. 18). To add versatility, a tailstock center set containing a variety of replaceable centers such as an inverted center and several centers used for pipe and hollow tube was specified. It was decided that a faceplate could easily be fabricated from plate steel as a part of the training process, and that dogs could be made as class exercises or purchased as needed.

Lathe Cutting Tools

An engine lathe is one of the most versatile machine tools ever invented. With the proper tooling it can be used to turn, face, drill, bore, groove, thread, and knurl (Appendix A pg. 19). The tools specified include a universal boring bar set with several boring bars and a universal tool holder. Since this set did not include the actual cutting tools, a variety of HSS tool bits were also included. These tool bits can be ground to any desired profile on a bench grinder with a standard fine grit abrasive wheel.

The specified turning and facing tools are all negative rake indexable insert types (Appendix A pg. 20). Indexable inserts are available in a variety of grades and materials. When one cutting edge of an insert gets dull, the machinist can index the insert to bring a new cutting edge into position. When all the available cutting edges are dull, an insert is replaced. The machinist always has a sharp cutting tool available and never has to sharpen a dull tool. To permit all types of turning and facing operations to be performed, tools with several different lead angles in both left and right hand styles using either square or triangular inserts were included. To simplify inventory, all tool holders of a certain shape use the same size insert.

A machinist in a maintenance machine shop is likely to be required to work on previously hardened parts or parts that have been welded prior to remachining. Negative rake tools, which are considerably stronger and more resistant to dulling than positive rake tools, were considered appropriate.

A grooving tool holder was also included. This tool holder serves double duty. Inserts of different widths and styles can be used when performing both grooving and threading operations.

Milling Machine Setup Tools

A milling machine is used to generate plane surfaces, slots, and grooves (Appendix A pg. 21). It can also be used to drill and bore holes in precise locations. On a milling machine, the workpiece is anchored firmly to the table, while the cutting tool rotates. Cutting action comes from feeding the table and workpiece under the spindle, or from feeding the spindle down toward the table.

Milling machine tables have T-slot grooves (Appendix A pg. 22) in the top surface. Fixtures and workpieces are held down to the table by using T-slot nuts, studs, clamps, and hex nuts. A fifty-two-piece clamping kit consisting of T-slot nuts, studs of various lengths, clamps of different sizes, a number of hex nuts, and a storage rack was specified.

To aid in setting up prismatic parts, a set of two angle plates (Appendix B Session #3) was also specified for purchase. These items are made of cast iron, machined, hardened, and ground, and have two flat surfaces at right angles, one of which is normally clamped down flat onto the table surface. The upright surfaces can be aligned parallel to either of the table's principal axes by using a dial indicator, enabling rapid alignment of workpieces by simply holding them up against angle plates.

They can also be used to create right angle surfaces on workpieces by clamping the appropriate workpiece surface to the angle plate with the desired perpendicular surface oriented up where it can be milled.

In order to align and hold cylindrical parts on a milling machine, a set of V-blocks is considered necessary. These items were not included in the initial order. It was decided that V-blocks and other types of setup hardware could be made by the maintenance employees as part of their training.

Milling Machine Cutting Tools

As is typical of milling machines of this size and type, the spindle is hollow so that a manually-operated drawbar can be used to secure tool holders and collets into the R-8 taper spindle nose (Appendix A pg. 23). Any spindle-mounted tooling must have an R-8 shank to be secured directly into the spindle. Tooling with other shank styles can be used if a suitable adapter with an R-8 shank is available.

In order to perform boring operations, an adjustable boring head kit and several cutting tool bits were specified. An adjustable boring head has a dovetail-shaped slide which is screw-adjustable, allowing fine adjustment of the swung diameter of the cutting tool.

The shop was already equipped with a complete set of collets and several end mills, but had no milling cutters suitable for performing slab-milling operations. For milling large, flat surfaces, the best tool available is a multiple-tooth shell mill (Appendix A pg. 23). A set of three shell mills of different diameters, all of which utilize indexable carbide inserts, was specified.

Drill bits are available in two different shank styles. Drills with diameters of 1/2" (13mm) or less usually have cylindrical shanks, and are normally held and driven by means of an adjustable drill chuck. Drill chucks and most larger diameter drills normally have a shank with a Morse taper (Appendix A pg. 23) of appropriate size. An R-8 to #3 Morse taper adapter (Appendix A pg. 23) was ordered to permit these tools to be used in the milling machine.

General Purpose Cutting Tools

There are a large number of general-purpose cutting tools that can be used on both the lathe and the milling machine. Twist drills of various types and sizes fall into this category. A complete set of drill bits in letter, number, metric, and fractional sizes up to 1/2" was specified. A set of standard length twist drills with Morse taper shanks from 9/16" to 1" was also included as well as a set of Silver & Demming style twist drills (Appendix A pg. 23) in the same size range. This type of drill is shorter than normal and has a 1/2" diameter cylindrical shank, allowing it to be held in a standard drill chuck.

Also included were several Morse taper adapters to allow tools with small Morse taper shanks to be used in machines that have a large Morse taper socket.

It is considered standard procedure to countersink a drilled hole prior to tapping. The maintenance department already had several tap sets on hand, but no countersinks, so an eight-piece set of chatterless multi-flute countersinks covering a 1/4" to 1" range was included.

Rounding out the order was a selection of end mills, center drills, and HSS square tool bits.

Part IV: Training & Skills Verification

Characteristics of a Maintenance Machinist's Job

A shop may have the best machine tools, measuring tools, and cutting tools available and still produce poor quality work if the personnel lack practical knowledge of how to use the equipment. Maintenance machinists in particular deal with a wider variety of technical challenges than production machinists.

Typical production machinists usually know the type of material they are cutting, have preset gauges available for checking vital dimensions, special cutting tools for specific tasks, a tool room to keep measuring tools calibrated, and are responsible for only one or two machining operations. Sequencing of operations is usually determined by manufacturing engineering, with most machining performed before parts are heat-treated.

Maintenance machinists must guess at the type of material they are dealing with, use standard measuring tools, make special cutting tools or adapt standard types for special tasks, keep their own measuring tools calibrated, and may be responsible for the total disassembly, repair (including welding), machining, fitting, and reassembly of a broken machine. The machinist must determine the sequence of operations, and damaged parts may have to be machined in the hardened condition, or annealed and rehardened after machining.

What a Maintenance Machinist Should Know

Before any training material could be developed, it was necessary to determine what a maintenance machinist should know. It was also necessary to inventory the existing skills of the maintenance employees, so that training time could be used efficiently.

The maintenance machinist of today performs the same types of job tasks on the same type of machine tools as the well-trained journeyman machinist of fifty years ago, and needs to have similar skills. With exception made for improvements in tooling and metallurgy, very few changes have been made in manual machining in fifty years. (This is not to imply that machining technology as a whole has been static or moribund for this period. The technology has advanced greatly, but along the lines of automation and computerization.)

It was agreed that the training would have both academic and manual components. Classroom instruction would include safety rules, shop math, the use of precision measuring tools, and familiarization with reference materials from sources such as *Machinery's Handbook*. The hands-on training would cover familiarization with the machines and their controls, setting up and securing workpieces, using measuring tools in practice, and performing various machining operations on each machine.

During informal conversations, several maintenance employees were asked about the following four areas: current skills, familiarity with machine shop practice and machine tool operation, math skills, and use of measuring tools.

All parties agreed that the current employee's skills were in problem diagnosis, disassembly, part replacement, calibration and adjustment, and reassembly. Some employees expressed a familiarity with some machine shop practices, but none admitted to having any real skill in machine tool operation. None of the employees expressed a very high level of confidence in applying certain math skills such as trigonometry for problem solving, although all seemed to welcome the opportunity for improvement. All believed that they were good at using precision measuring tools such as micrometers and vernier calipers, but expressed doubts about the ability of their coworkers to use these tools properly.

The conclusion reached was that the employees needed training in everything from math and micrometer reading to tool selection and machine tool operation.

Using Computer-Based Technology for Training

Computers have been used to generate training and educational material for many years. This typically involved the use of a Computer-Aided Design (CAD), word processing, or a spreadsheet program to generate static documents for handouts and reports, or the use of highly specialized interactive drill-and-review programs.

What had long been needed was interactive multimedia-capable software that was versatile, flexible, and easy to use. This need is being met with the development of platform-independent programming languages such as HyperText Markup Language (HTML) and JavaScript[®], coupled with Web browsers such as Netscape Navigator[®] and Microsoft Explorer[®].

Both of these popular Web browsers can read a wide variety of graphic, sound, and text file formats, have at least two built-in interpreted programming languages, and provide e-mail support. Files can be accessed and read by locating them with an Internet Universal Resource Locator (URL), a location or address where the file can be found. By using hyperlinks (a picture or line of text in a document that when selected with a mouse opens another document), related documents can easily be accessed in a nonsequential, free-form manner.

It was felt that developing training material specifically for use with a Web browser would offer a number of advantages in this situation. It was agreed that training materials would also be provided as hard copy handouts. At the conclusion of training, the resulting collection of documents would be placed on a CD-ROM disk and supplied to Mr. Hooper and Mr. Gries.

The Machinist's Assistant is Born

The intent was to create a Web site of interrelated documents accessible through a standard interface. Many of the documents would be generic in nature, and would provide information and perform functions common to the machine trade in general. Other documents would be specific to GE's machine shop and equipment. It was believed that once this suite of documents was developed, it would be very little trouble to customize it for other users.

The end result is called the "Machinist's Assistant" (Appendix A pg. 24). Although the software is a finished product future changes will undoubtedly be required because the nature of Web-based materials should be one of constant modification and change. A combination of HTML and JavaScript is used throughout. The software has been tested to ensure correct operation in Navigator 3.0/4.0 and Explorer 3.0/4.0. No version-specific language extensions or nonstandard coding has been used, so it should run properly on any later version of either of these two common browsers.

Software Features

The main structure of the Machinist's Assistant is provided by a very short program that divides the browser window into four unequally-sized frames. The frames are resizable to permit users to adjust the display, which is optimized for a screen resolution of 800 x 600 pixels. The upper left frame is simply used as a text box to describe the contents of the lower left frame. The lower left frame contains a column of buttons labeled "Welcome", "Safety Rules", "Eng. Lathe", "Vert. Mill", "Cutting Info.", "Mat'l Index", "Meas. Tools", "Shop Math", "Go Back" and "Go Forward". The first eight buttons are hyperlinks to the main areas covered by the "Machinist's Assistant", with the last two buttons providing true back and forward navigation functions.

The upper right frame displays the word "Welcome" while the file containing the welcome screen loads into the lower right frame. After this document is fully loaded, the upper right frame displays the location of this document. This action was incorporated to provide a "softer" introduction to users who may have a slow network connection; when accessed by a fast computer from a local hard disk the "Welcome" goes by almost without notice. Many users appreciate knowing the location of the document they are viewing. An undocumented "feature" of most Web browsers is the inability to correctly display the location of a document displayed in a frame. The location of the document that created the frame is what is normally displayed in a browser's "Location" window.

All documents are displayed in the lower right frame. Each document has a common header that uses JavaScript code to write the document's URL in the upper right frame. The main page for each area is an index of the hyperlinked documents within that area.

The Proposed Training Sequence

The training sequence was to be as follows:

- Classroom training in basic shop math and reading and using precision measuring instruments.
- Follow-up exercises in applying trigonometry and reading measuring instruments by using the milling machine to drill a bolt circle. These also include familiarization with the parts of a milling machine using printouts from the Machinist's Assistant.
- Classroom training in calculating speeds and feeds for machining operations, and the use of reference materials such as *Machinery's Handbook* and the Machinist's Assistant.
- Classroom familiarization with the setup hardware and basic cutting tools used on the milling machine.

- Follow-up exercises on the milling machine using the setup hardware to align and secure parts to the table, followed by performing basic machine operations such as milling, drilling, and boring.
- Classroom familiarization with the parts of a lathe, basic lathe operations, and how work is secured in a lathe.
- Follow-up exercises showing a variety of workpiece holding methods and machining operations on the lathe.
- Advanced training on the milling machine, possibly including use of a dividing head to facilitate milling splines and gears.
- Advanced training on the lathe, including internal and external threading operations.

Refresher-Training and Document Generation

The first group of maintenance technicians who were to be trained in both the Lexan[®] and CPP area had previously received some training in basic machine tool operation. Each group consisted of eight employees. Most had received their machine shop training as part of their general apprenticeship training. This part of their apprenticeship training had taken place at a local high school, in cooperation with the local school corporation. During this course the students had received a three-ring folder filled with documents related to machining and machine operation, including tables of feeds, speeds, material properties, and tools. These technicians had all the information necessary to perform basic machining operations, but were unsure of how to apply this knowledge.

This made clear one of the major problems that the technicians at GE must overcome, and that the author wanted to effectively deal with. The main task of the technicians at GE is to repair and maintain the production equipment. Because of the variety of tasks that are performed, and the random character of breakdowns that would require machining to effect repair, several

months may pass before a technician needs to use a milling machine or lathe. Being trained on equipment which may differ significantly from that used on the job, and allowing months to pass between the use of such equipment is a poor way to develop and maintain competency. Lack of practice causes knowledge to fade, confidence to dissipate, and skills to erode.

In a pre-training discussion the technicians expressed two main concerns. They were confused by the multiplicity of controls on the lathe and milling machine, and they were unsure how to apply the knowledge they had to setting up and running each machine. Refresher-training would primarily consist of familiarizing the students with the specific machines and hardware they would be using in their respective shops.

It was decided that the best way to deal with this group of technicians was to generate training materials by annotating the previously-taken digital photographs with the names of the machine controls, and to use the resulting documents along with hands-on training to refresh the technicians' skills.

The procedure used to generate this material is as follows.

- The machines in each shop were photographed from several different angles. The camera used was a Kodak DC210 with a resolution of 1152 x 864 pixels in full 24-bit color.
- The digital photographs were then downloaded to a personal computer, a 486DX2-66 running Windows 95, where they were saved in Joint Photographic Experts Group (JPEG) format.
- The image files were opened in LView Pro[®], where they were electronically enhanced for color and brightness, cropped to remove unwanted details, and scaled to a size that would display properly in a Web document. These were then saved in the standard Windows Bit Map Picture (BMP) format.

- The BMP files were opened in MS Paint[®], the graphics program that comes with Windows 3.x/95. The width of the images was increased by 300 pixels to provide a blank space on the right hand side for text annotation to be typed in. This text was then selected with the selection marquee and dragged into position on the photograph. Several colors for the text were tried, with a bright green selected for maximum contrast with the underlying photograph. This showed up well on-screen but poorly on the printed page, as it tended to blend in to the photograph and appeared indistinct. Changing the selection option to allow the white background under the text to be picked up along with the green foreground text corrected this problem. This allowed the text to show up well both on-screen and when printed, and helped to mask some of the background clutter in the photographs. Leader lines of the same color as the text were then drawn to connect the text to the appropriate machine component. Finally the image size was restored to its original dimensions, eliminating the extra space on the right, prior to saving the updated file in BMP format.

- The images were reopened in LView Pro[®] and immediately saved in Graphic Interchange Format (GIF) format. Although Web browsers can display images in both JPEG and GIF formats, the quality of the annotated image was very poor when saved as a JPEG format file. The text was blurry and appeared to be "smeared" across the image. This did not occur when the image was saved in GIF format. The file size was also significantly smaller when GIF format was used, allowing for the image to load quicker when displayed.

- The HTML documents that would display the image on-screen were coded, along with any intermediary documents that would provide for navigation to these illustrated documents. HTML Writer[®], a shareware HTML document authoring program, was used for all document creation and editing. This program is basically a specialized text editor and does not have a "What You See Is What You Get" (WYSIWYG) interface, but it does allow the file being edited to be opened concurrently by another program, such as a Web browser. This allows the document being edited to be tested using a real Web browser.

(Various types of "code generating" WYSIWYG-type programs are available, but experience has shown that the files generated by these programs tend to be larger than the lean code generated by straight text editors.) These documents were all included in the framework of the Machinist's Assistant.

- The illustrated documents were printed out, punched for a three-ring binder, and used as handouts. All printing was done on a Hewlett-Packard DeskJet 890C color inkjet printer.

Four refresher-training sessions were held, two in the Lexan[®] area and two in the CPP area, each of four hours duration. Four employees attended each session. The handout material was used as a guide to ensure that the name and function of each part and control on the lathe and the milling machine was pointed out.

The milling machine head can be oriented in an infinite number of positions, and must be adjusted properly to perform accurate work. Students were shown how to use a center finder set and finger indicator to square up the head to the table surface, followed by instructions on how to accurately align a milling machine vise with the X-axis of the machine table. A piece of scrap steel was clamped in the vise and a small slot was cut with an end mill as a means of illustrating the simplest of milling procedures.

The technicians involved seemed to feel that these sessions, despite their brevity, were helpful. Several of the technicians realized that they had forgotten more of their prior training than they had initially thought, and asked to participate in the full ten-week training that was to follow. This was approved by their respective managers.

Basic Training Course - Background

The two classes of technicians that were to take the full-length machine shop training course consisted of eight students from each area. Although originally only the mechanics in each area were scheduled to take these classes, shop rules dictated opening these classes to all maintenance personnel, including electricians. The class composition therefore consisted of a fairly even mix of mechanics and electricians. Most of the students had little or no prior machining experience, although several of the students had received some training as indicated above.

Training in the Lexan® area was scheduled for Tuesday and Thursday mornings from 7:30 to 11:30. This would permit technicians on regular shifts and swing shifts to attend one class each week. The employees in the CPP area were only scheduled for one session per week on Wednesdays, so it was expected that there would be times when swing shift employees would not be able to attend. Mr. Gries was aware of this fact and agreed that these employees would just have to keep up as best as they could.

One other problem that was recognized prior to the beginning of training was the possibility that one or more technicians would need to be pulled from the class to perform emergency maintenance. All parties involved understood that the students could only learn if they were present to receive instruction, but the company had the responsibility to use their human and economic resources efficiently. It is the nature of GE's continuous flow production operation that while there are a number of redundancies in their production systems, there are still a number of key electrical and mechanical components that might fail and need to be immediately repaired. It was understood that such absences would be kept to a minimum.

In order to support absent employees, it was agreed that extra copies of training materials and handouts would be left in an obvious location in each of the maintenance shops where employees could pick them up at a later time.

Observations and Educational Methodology

As a professional educator with teaching experience at the high school, vocational school, and university level, the author has developed a methodology for teaching students technical skills. This methodology has been developed by studying the types of jobs that technicians perform and by observing student behavior.

People who trend toward technical occupations that require well developed manual skills, such as welding, machining, and machinery maintenance, tend to be more concrete and less abstract in their thought processes than people who trend toward careers of a more academic nature, such as engineers. The action/result cycle tends to be shorter for technicians than for engineers. Welders, machinists, and mechanics perform their jobs on problems that are current and evident, and where success or failure can be easily determined. This is not a reflection of the relative intelligence of technicians as compared to those with careers in other areas, but it does indicate that technicians learn best by performing manual tasks which have observable short term results.

Students learning a professional skill should be treated with the dignity and respect due any professional person. This is especially important when training people that are already employed as skilled technicians.

Communication should take place in both directions. The instructor should know more than the student about the particular set of skills to be taught, but the student probably knows more about how these skills will be used. Listening to the student can help the instructor use the available training time efficiently.

Based on these observations, the following methodology was proposed for machinist training:

- At the start of the course give the students an overview of the topics that will be included in the training regimen.
- Give the students enough reference material to allow skills training to proceed.
- Show students how the reference material should be used.
- Show students where additional reference material can be found.
- For each skilled task being taught, explain what is to be covered, demonstrate how the task is performed, have the student perform the task, and then review the material covered and the students' performance.
- Minimize the time spent talking about a task and maximize the amount of time students spend performing each task. Students should get their hands on the machinery early and often.
- Review and reinforce the students' knowledge whenever possible by stressing the interconnection between previously learned concepts and the current topic.
- Praise students when their performance is satisfactory, and employ positive criticism when their performance is unsatisfactory. Maintain a positive class attitude by encouraging the students whenever possible.
- Encourage students to think by asking questions that will require the students to draw on their existing knowledge and skills to reach a satisfactory answer. The synthesis of knowledge is the first step in teaching students to teach themselves.

Educational Delivery and Document Generation

The training proceeded along the lines of the proposed training sequence. Since students would receive hard copy handouts every week, three-ring binders were supplied to help keep the handout material together. (Note: Weekly lesson plans and a copy of all the handouts are included in Appendix B.)

Some mechanical difficulties were encountered with the lathe in the CPP area, and as a result, a slight deviation from the proposed sequence was required, but the flexible nature of the training program and a plant-wide yearly shutdown allowed enough time for this machine to be put back into operation.

The training material was generated one or two weeks in advance of its use. The graphic elements of the documents consisted of a combination of digital photographs and bit-mapped graphics. As an example, training materials for micrometer reading were created by using MS Paint® to create a 1200 x 400 pixel BMP file showing a completely annotated micrometer barrel, with each .001" of the barrel equal to one pixel. Another illustration was prepared showing a micrometer thimble in the same exaggerated scale. By renumbering the scale on the thimble and saving each change as a different file, twenty five separate files, each showing one of the twenty five markings on the thimble where it would be aligned with the index line of barrel, was created. These twenty-six files allow the author to cut and paste images to create any micrometer reading from .000" to 1.000" in .001" increments.

Two more graphic files were created at very large size, one of a vernier beam and another of a vernier scale. These two files can also be combined and renumbered to create any vernier reading desired. A vernier scale reading exercise document was prepared in a similar fashion to the micrometer reading document.

Skills Verification of Employees

Both Mr. Hooper and Mr. Gries were insistent that skills verification be included as part of any training effort. GE's lock-out/tag-out procedures, which are part of its ongoing safety effort, require individual machines in each shop to have their power supplies padlocked in the off position. Only employees who could work safely and use the machine tools properly would be given keys to the machines in the machine shops.

The tests established for skills verification included both academic and hands-on components.

The academic component included basic trigonometry, calculation of feeds and speeds, and general questions relating to safety and machine use.

During the hands-on test, students were given a shop sketch of a shaft that required two turns of different diameters and lengths, with a longitudinal keyway slot in one of the turns. The students had to select the proper tooling, set up and secure the piece in the lathe, and generate the turns. The students then had to select the proper tooling, set up and secure the piece on the milling machine, and cut the keyway. This test encompassed all the skills students should have learned, including the use of measuring tools.

Seven of the eight students in the Lexan® area took the skills verification exams. One student was placed on extended medical leave for conditions unrelated to the training. Six students passed both exams and were issued certificates. One student failed both exams. Management agreed to send this student to a formal apprentice-level machinist training course if desired.

Only one student in the CPP area elected to take, and pass, the tests. There were two reasons for the loss of seven students. Four of the students were electricians; they found the idea of taking the class more appealing than the nature of the work involved. Management policy was to allow but not require any technician to take this class. These students were allowed to finish the training but were not required to take the tests. Three of the students were ICI-employed union apprentices, with the contractual obligation of taking a formal machine shop course through a local technical college. Their mandatory attendance in this offsite class started at the end of the onsite machinist training. They also decided to forego taking the skills verification tests, since management agreed that passing the apprentice training course would be a satisfactory verification of skills. During post-training interviews, these students indicated their satisfaction with the onsite training. They felt better prepared upon starting their apprentice training course and were quicker to adapt to the different brands and styles of machines in the training shop than other apprentice students.

After training was concluded, both Mr. Hooper and Mr. Gries expressed satisfaction with the end result of the training program.

The CPP shop also receives some external business along with the training. Mr. Gries had obtained work for rebuilding the shop's engine (cost approximately \$31,000) and for manufacturing a new pump (approximately \$27,500). In other words, the work in these and money was too high, so the engine work would have to be taken out of profits and removed from the shop. Consultations with Mr. Gries regarding alternatives to totally overhauling or replacing the engine cost \$100,000 to \$30,000 have enabled Mr. Gries to spend approximately 11% of the amount to obtain essentially the same result.

Summary and Conclusions

The stated scope of this project was to lay out a machine shop, verify the location and leveling of the machines in the shop, specify and order tooling to equip the shop, and train the technicians who would use the shop. The scope was enlarged to include machinist training of technicians in a similar shop located in the same industrial complex. All of these activities have been successfully completed to the satisfaction of the maintenance managers of each area.

Other activities related to but outside the scope of this project have benefited GE and reinforced the correctness of the management's decision to enhance the machine shops and the training of the employees.

Several times during the course of training, technical assistance was provided to Lexan[®] technicians who were performing some machine work on actual parts used on the machines in the production area. Once the lathe was used to check a two-lobed blower shaft for straightness, a task that is currently subcontracted out. Another time an overly long fan extension shaft had each end cut off and faced square using the lathe; this type of work is also currently being outsourced.

The CPP shop also received some economic benefits along with the training. Mr. Gries had obtained bids for rebuilding the shop's engine lathe (approximately \$30,000) and for purchasing a new lathe (approximately \$27,500). In either case, the cost in time and money was too high, as the existing lathe would have to be taken out of service and removed from the shop.

Consultations with Mr. Gries regarding alternatives to totally overhauling or replacing the lathe at a cost of \$27,500 to \$30,000 have enabled Mr. Gries to spend approximately 11% of this amount to obtain essentially the same result.

Technical assistance in selecting tooling and evaluating equipment upgrades was also provided, thus enhancing the capabilities of the CPP machine shop.

Of continuing benefit is the training materials, organized into a website called the Machinist's Assistant. A CD-ROM disk with customized versions of this program has been given to Mr. Hooper and Mr. Gries. The information can be easily accessed at a later date by new employees or by employees needing to refresh their memories.

The Machinist Assistant was designed with about two-thirds of the material common to general machine shop practice. The remaining one-third can easily be customized to meet the needs of a specific machine shop. A modified version of this program has been placed on the server maintained by the USI School of Science and Engineering Technology, making the content available to anyone with access to the Internet.

American Iron and Steel Institute (AISI) - An industry group comprised primarily of producers and consumers of ferrous materials.

bedways - the accurately machined surfaces of a lathe frame that run parallel to the rotational axis of the spindle. The tailstock and carriage can be positioned anywhere along the bedways without changing their position relative to the axis of spindle rotation.

Bit Map Picture (BMP) - A computer graphics format that assigns a discrete numerical value to each pixel in an image. Capable of great detail, BMP files tend to be larger than either JPEG- or GIF-format files.

bolt circle - A pattern of holes that are equiangular and equidistant from a central point. An example would be the holes in a car's wheel that fit over the studs in the wheel hub.

bore - A machining operation which enlarges an existing hole to a larger diameter.

bubble level - A tool consisting of a glass tube filled with a liquid and a small volume of air which is aligned parallel to a plane surface. The force of gravity and the difference in density between the two fluids causes the bubble to float to one end of the glass tube when the parallel surface is not aligned perfectly horizontally.

CADKEY® - A Computer-Aided Design (CAD) program

carbide - A ceramic compound consisting of one or more metal atoms and one or more carbon atoms. High compressive strength and hardness coupled with resistance to softening at elevated temperatures make carbide useful as a cutting tool material

change gear - a gear on a lathe normally located in an easy to access location which can be easily changed by the lathe operator to provide for a different range of feed rates and/or thread pitches.

collets - see *expanding collets*

Computer-Aided Design (CAD) - The process of using computers to help design and document structures and devices.

Computer Numerical Control (CNC) - The use of a computer to control the operations of a machine tool

countersink - A tapered, conical transition between a hole and the surface it penetrates, or the tool which creates this feature. Normally used to prepare a hole for tapping or to create a recessed bearing surface for a flat-head fastener.

crystalline polymer - A type of polymer with a highly orderly molecular structure, as opposed to the amorphous (formless) structure common to most polymers.

dial caliper - A measuring tool with a fixed beam and a moveable scale with attached dial. Readings are taken from the beam and the dial.

dog - a work holding and driving device used on a lathe when turning shafting between centers. It is clamped to the shaft by means of a screw and driven by a projection on the faceplate.

drawbar - A long bolt used to secure a tool into the spindle of a machine tool by passing through the hollow spindle center where it is screwed into the base of the tool.

drill - The process of creating a hole in a blank surface, or the tool which performs this function

end mill - A rotary cutting tool which is designed to cut in a direction perpendicular to its axis of rotation. Used primarily to cut slots and grooves.

engine lathe - A machine tool which rotates parts around a horizontal axis, permitting cylindrical features to be machined.

epoxy - A two-part polymeric material often used as a glue which polymerizes to form long-chain molecules when mixed together.

expanding collets - A type of work-holding device used to accurately secure standard size materials and tools into a machine spindle.

faceplate - an attachment to a lathe spindle, it acts as a flywheel and as a means to transmit torque to a shaft by means of a dog.

feed - The distance a tool traverses laterally for every cycle (a single stroke or revolution).

follow rest - A lathe accessory which attaches to the carriage and helps reduce deflection of a long, slender workpiece.

four-jaw chuck - A lathe chuck with four jaws which can be moved independently to securely hold a workpiece of almost any shape.

gantry crane - A overhead crane supported by a structure which rolls on elevated rails.

gib - A tapered, wedge-shaped part typically used to take up wear between parts which slide on dovetail ways.

Graphic Interchange Format (GIF) - A graphic file format which permits transparency and basic animation but which limits the resolution to a maximum of 256 colors

High Speed Steel (HSS) - A special grade of alloy tool steel containing cobalt and/or molybdenum and/or tungsten. These alloys form ceramic crystals within the iron matrix when heat treated, giving the resulting material high strength, hardness, and heat resistance.

HyperText Markup Language (HTML) - A device-independent document formatting language.

indexable insert - A cutting tool, typically ceramic, which has multiple cutting edges and which can be reoriented in a tool holder to bring each edge successively into alignment.

intranet - An internal communication network designed to link up computers over a limited area.

JavaScript® - A programming language used to augment and extend HTML by providing the capability to modify documents in real time.

jib crane - A type of crane hung from a horizontal beam which is attached to a wall or column.

Joint Photographic Experts Group (JPEG) - A group of computer graphics professionals which has developed a photo file format with a variety of compression ratios.

knee - as part of a knee-and-column type of milling machine, it is a triangular element with two accurately machined right angle faces. One face mounts to the column and can be adjusted vertically; the other face mounts to a saddle, permitting movement toward and away from the column.

Lexan[®] - A patented polymer used for consumer items such as CDs and car parts.

machinist's vise - A workpiece holding tool consisting of a heavy frame with a fixed jaw and a sliding jaw with a screw or cam for tightening, normally used on drill presses and milling machines.

micrometer - A precision measuring tool with a fixed barrel and rotary thimble.

millwright - A mechanic whose primary skill is in mounting, leveling, and adjusting machine tools

Morse taper - A cylindrical taper used to hold tools by friction forces into the spindle of a machine tool.

negative rake - The geometry of a cutting tool that has the cutting face inclined toward, instead of away, from the surface being cut.

Occupational Safety and Health Act (OSHA) - The Federal law which specifies the type of safety devices and procedures that must be followed when performing most job tasks.

pixel - The smallest addressable element of a video screen.

precision - The closeness of an indicated value to the actual or ideal value.

quill - a machine element which can hold various types of tools that can be traversed in an axial direction at a controlled rate.

R-8 taper - A type of taper commonly used on the spindles of vertical milling machines and the shanks of tools which fit into the them.

saddle - as part of a knee-and-column type of milling machine, it is a machine element that mounts atop the knee and supports and guides the table.

screw-type extruders - A type of thermoplastic extrusion machine which consists of a screw mounted inside a hollow tube or barrel. Rotating the screw pushes the plastic through the barrel and into a die.

shell mill - A type of milling cutter used primarily for slab-milling large areas.

slab-milling - The process of removing a large amount of material from the top of a workpiece by means of a rotating cutting tool.

Society of Automotive Engineers (SAE) - A private industry group consisting primarily of automotive manufacturers and suppliers.

spindle - The rotating part of a machine tool. On a milling machine the spindle rotates the tool; on a lathe the spindle rotates the workpiece.

steady rest - A lathe accessory which anchors to the lathe's bed and supports one end of a workpiece, freeing up the tailstock for drilling, boring, etc.

surface grinder - A machine tool which uses an abrasive wheel to grind flat surfaces on a workpiece.

tailstock - An element of a lathe, it can be moved along the bedways to locate it at any distance from the headstock. It is used for drilling holes or supporting the center of a shaft.

tailstock center - A lathe accessory which fits into the tailstock and supports one end of a long workpiece.

tapping - The process of generating internal threads

threading - The process of generating internal or external threads

three-jaw chuck - A lathe chuck with three jaws which move synchronously to align a round or hexagonal workpiece concentric to the spindle's axis of rotation.

tolerance - The maximum variation in size or shape which will still yield an acceptable part.

torque - A twisting force.

Universal Resource Locator (URL) - The "address" where a document can be found on the Internet.

V-blocks - An item of milling machine setup hardware consisting of a block with a flat bottom and a V-shaped upper surface. Used to hold a cylindrical workpiece in alignment.

vernier caliper - A measuring tool with a fixed beam and a moveable scale. Readings are taken from the beam and the vernier plate.

vertical milling machine - A machine tool with a spindle which rotates a cutting tool around a vertically-oriented axis.

"What You See Is What You Get" (WYSIWYG) - A phrase used to describe the phenomenon of a having a computer's visual display appear exactly the same as its printed display.

Part VI: Bibliography

A number of books and references were used during the execution of this project. Many were of the "how-to" variety relating to HTML and Javascript® programming. Other references included various vendor sales catalogs. None of these are included in this listing. The books listed here were consulted for information on machining principles, material properties, and shop layout.

Robert E. Green, ed. *Machinery's Handbook*, 25th ed. Industrial Press, Inc.: New York NY. 1996
ISBN 0-8311-2575-6

Roberts and Lapidge *Manufacturing Processes* McGraw-Hill Publishing Co.: New York NY. 1977
ISBN 0-07-053151-X

Theodore Baumeister, ed. *Marks Standard Handbook for Mechanical Engineers*, 8th ed.
McGraw-Hill Book Co.: New York NY. 1978

Fred E. Meyers *Plant Layout and Material Handling* Regents/Prentice Hall: Englewood Cliffs
NJ.1978

Part VII: Appendix A - Correspondence and Illustrations

Date: Sun Jul 27 15:16:56 1997
From: "Keith G. Benedict" <kbenedic@comsource.net>
To: Curtis Hooper <curtis.hooper@gepex.ge.com>
Subject: Machinist Training

Curt-

Let me share some thoughts before I make a formal proposal to you for assistance in setting up a maintenance machine shop and training your people to use the equipment.

(a). If I need to communicate with you (or any other entity that I do consulting work for) via Email I will try to always use the service provider (Comsource) that I pay for, rather than use the University's service. I do this to stay on the side of the angels as far as business ethics are concerned. I don't THINK I would get in trouble if anyone checked my Email useage, since outside consulting by the faculty is expected and encouraged, but I would rather keep my private business private and separate from my University business. This ensures that my private business is conducted outside of my work hours; the result is that I send out Email early in the morning or in the evening.

Of course I can't control how someone sends me mail, so you are free to use either my University Email address or my Comsource address. I check them both daily, but I always check my Comsource mail in the morning before I go into work; sometimes I don't get the chance to check my USI Email until later in the day.

USI Email: kbenedic.ucs@smtp.usi.edu
Private Email: kbenedic@comsource.net

(b). My rate is \$50/hour. For teaching I charge only for the time on site, with the exception of courses that require lots of outside grading. I don't usually charge for prep time or time spent generating handouts, etc., and in this case, as long as we agree that any materials I generate for this training are mine to use in other classes I might teach elsewhere, this would be the case. I certainly understand and agree that any material specific to GE will NOT be used elsewhere without permission, but I don't see anything like that happening here. I simply want to be efficient with my time while keeping your costs at a reasonable level. (I have also harbored thoughts for many years about writing a book about repair and maintenance welding and machining.)

(c). Since I must be paid as an employee of one of your approved vendors, if possible I would like to have taxes, etc. deducted. This keeps me from having to file quarterly estimated tax payments or getting a nasty suprise on April 15th.

(d). At this point it looks as if Fridays will be the only time I have a our hour time block available. This might change after final enrollment is verified, but I won't know this until the semester starts. Classes begin on Tuesday, September 2, but I will probably get my final schedule Thursday or Friday of the prior week.

(e) Until then I would be glad to work out something with you concerning shop layout, tool and equipment purchases, etc. For technical consulting I can either charge you by the hour (\$50) or by the job, whichever you prefer. For shop layout I need to be on site to take measurements, but I will probably do a lot of the work at home on my own computer system. For generating a list of tools and equipment needed to set your shop up right I would need to be on site long enough to

document what you currently have. Do you want me to match up tools w/your approved vendors catalog offerings? I would be glad to prioritize any items to allow you to use your budget intelligently. With this out of the way, here is what I think should be included in maintenance machinist training, along with an estimate of the time required. Note that (C) represents the use of a classroom, and (S) represents the use of the shop.

Session 1 (4 hrs)

- (C) Introduction to course, goal establishment.
- (C) Reading micrometers and verniers.
- (S) Introduction to the milling machine.
 - Controls and components
 - Capabilities

(This would probably include a demonstration of various milling operations. Students would also be given some out-of-class work using mikes and verniers, and a handout of a milling machine with the controls unlabeled for them fill in.)

Session 2 (4 hrs)

- (C) Milling machine tooling (endmills, facemills, drills)
- (C) Calculation of feeds and speeds.
- (S) Application of feeds and speeds to actual milling processes.
- (S) Start milling project (3-4-5 blocks)

(Students should finish the milling operations out of class. Handouts would include reference tables with feeds and speeds for various materials, and exercises using the tables to perform calculations.)

Session 3 (4 hrs)

- (C) How to use a dial indicator to align parts.
- (C) How to use a center finder to locate features on a part relative to table location.
- (C) Use of basic trigonometry to convert angular displacement to X-Y coordinate moves.
- (S) Use of dial indicator to align parts.
- (S) Demonstration of use of trigonometry to drill bolt circle.
- (S) Use of center finder to find corners of 3-4-5 blocks for drilling.
- (S) Use of table feed lead screws to locate holes and features for positioning.

(Students should finish drilling 3-4-5 blocks out of class. A handout covering basic trigonometry will also be given out and should be completed out of class.)

Session 4 (4 hrs)

- (C) Review of feeds and speeds, and trigonometry.
- (S) Demonstration of other milling machine operations, including setting and realigning mill head.
- (S) Demonstration of use of dividing head/rotary table for milling radii, angular slots, and drilling holes.

At this point, the students should have their 3-4-5 blocks milled and drilled, ready for heat treating. I don't know if you can send employees off GE property for training, but it would be nice at this point if they could come to USI to get some hands-on experience with heat treating. In a four hour block of time, it would be possible to teach a little basic ferrous metallurgy while the 3-4-5 blocks are being heated, quenched,

and tempered. If this is not possible, then you can send the blocks out to a local heat treater, or I can do it or let some of my MET411 Materials students do it. Your choice...

I know we discussed "certification" or competency testing. This needs to be discussed further. Would you rather have this done at the end of instruction for each machine, or would you rather wait until the end of the lathe and grinder training and test comprehensively? Share your thoughts, please.

After the blocks are hardened, there are two ways to proceed. We can start training on the surface grinder, and finish up the 3-4-5 blocks, or we can start on the lathe. My own choice would be to start on the surface grinder, since this would take about eight hours of instruction and would finish off the student's first project. It would also transition nicely into a lathe project I have in mind (a tool grinding fixture) but again it is your choice based on your needs.

If this were done on a three week rotation, it would take 12 to 15 weeks to complete the milling machine section, and 6 more weeks to finish the grinder section. I estimate that it will take 16 to 24 hours for lathe training, since lathes are, in general, more versatile than mills. I don't want to go any further with this right now; I'd like to get some feedback from you. Let me know how you wish to proceed.

Keith

Date: Sun Nov 23 21:57:47 1997
From: "Keith G. Benedict" <kbenedic@comsource.net>
To: Curtis Hooper <curtis.hooper@gepex.ge.com>
Subject: Machine shop

Curt

I have generated a list of tooling and accesories needed to equip the shop. I have also generated a drawing of the new shop layout.

I would really like to lay out the shop floor to ensure that the equipment ends up in the right places. I plan on faxing the drawings to Terri M. today along with this request. I can be on-site Tuesday afternoon (around 2 pm) to double check measurements and put chalk lines on floor. Let me know on this.

As to anchoring down lathe: I plan on calling a friend of mine at G. Koch to see how they do it. Initial thoughts go something like this: Use at least six (would prefer all ten) holes (four at headstock, two at tailstock) with hollow adjusting screws in them to bolt down through to floor. Need to get ten screw adjustable wedge-type machinery leveling shims. Need six small steel plates with hole in center just barely bigger than hold down bolt. (The leveling screw must bear on this plate.) Thickness should be same as thinnest size of adjustable shims. When anchoring lathe down, put plates under lathe. Lower lathe until highest corner sits on plate. Level lathe with other five screws. (Probably need to put bolts through screws and into floor anchors loosely so lathe doesn't move off position.) Snug down all screws evenly, and recheck level. Insert leveling shims and snug up. Retighten screws evenly to final torque. Recheck shims. Test lathe.

As to equipment and tooling: Do you have a preferred supplier? How and from who do you intend to purchase this stuff? Would you like me to identify vendors and/or specify items from vendors with part #s, cost, etc.? Would be glad to do so and it might simplify matters. Please let me know on this.

Looks like you will have to move at least two and maybe three of the electric services during relocation. Need to talk to you about final locations. Is it OK to use support structure of breaker box (it's 2" x 2" square tubing) as part of storage rack?

You mentioned a hanging crane of some sort - will this interfere with electrical? Need to think about this before electric service is moved. For your info, a 6" diameter steel shaft 72" long weighs about 1940 pounds. Your people have a better idea of normal size/weight of work you might encounter. Lathe has about 15" diameter swing over carriage with about 72" between centers.

Rest of this is tool list. Will bring finished copy Tuesday to give you. Will try to call you Monday afternoon.

Milling Machine

Accessories
Clamping Kit

(Should have 6-8 strap clamps, 12-16 studs of different lengths, T-nuts, washers, and nuts)
One pair large V-blocks

One pair small V-blocks
One pair large angle plates
One pair small angle plates
Two sets 3-4-5 blocks

Tooling

R-8 to #3 Morse taper adapter
Set of Silver & Demming style drills (these shorter than normal twist drills have a 1/2" cylindrical shank and can be used in a standard 1/2" drill chuck)
(Should cover 9/16 to 1-1/4 diameter)
Adjustable boring head with tooling
2" 3 flute indexible carbide mill
(Should use positive rake triangular inserts)
2-1/2" to 3" multi flute indexible carbide mill
(Should use square inserts)
Assortment of two and four flute HS steel end mills (1/4", 3/8", 1/2")

Lathe

Accessories

Faceplate
Lathe drive dogs 0 to 8" (used to drive shafting when turning work between centers)
Taper attachment
Live tailstock center (#5 Morse taper)

Tooling

Morse taper adapters/sleeves
#5 to #4, #4 to #3, #3 to #2
Small boring bar w/holder
Medium boring bar w/holder
Large boring bar w/holder
Right hand indexible carbide tool holder (square, negative rake, 15 lead angle)
Left hand indexible carbide tool holder (square, negative rake, 15 lead angle)
Right hand indexible carbide tool holder (triangular, negative rake, 0 lead angle)
Left hand indexible carbide tool holder (triangular, negative rake, 0 lead angle)
Indexible carbide UN profile threading tool holder
Supply of HS steel and carbide inserts for above tool holders

General

Measuring Instruments

Outside micrometers 0 to 12" w/standards
Small hole gages
Telescoping gages
Inside micrometers 6" to 12"
24" vernier height gage
0 to 6" vernier, dial, or digital calipers
0 to 12" vernier, dial, or digital calipers
0 to 48" vernier, dial, or digital calipers
Several 12" steel scales with combination heads, protractor heads, and center heads
Several 24" steel scales to fit heads
48" steel scale
Machinist's squares, 6", 12", 24"

Tooling

Set of jobber length HS steel twist drills, fractional 1/16" - 1/2"
Set of jobber length HS steel twist drills, letter sizes A - Z
Set of jobber length HS steel twist drills, number sizes 0 - 80
Set of jobber length HS steel twist drills, metric sizes 1 mm - 13 mm
HS twist drills 17/32" to 1-1/4", morse taper shanks
Chucking reamers, solid 1/4", 3/8", 1/2"
Center drills in various sizes
Set of coarse and fine thread taps

Accessories and Miscellaneous

Lockable cabinet for lathe tools and accessories
Lockable cabinet for measuring instruments
Heavy table w/vises
Rack to hang lathe chucks

--

Keith G. Benedict {kbenedic@comsource.net}

Senior
Will find a way around to get with you. Thank
W. G. H. H.
Senior
Senior
112/831-7551
112/831-7551; Fax 112/831-7551

Date: Mon Nov 24 20:16:25 1997
From: "Hooper, Curtis (GEP)" <Curtis.Hooper@gepex.ge.com>
To: "'kbenedic@comsource.net'" <kbenedic@comsource.net>
Cc: "Conyers, Wayne (GEP)" <Wayne.Conyers@gepex.ge.com>
Subject: RE: Machine shop

Keith, I'm not sure I completely follow the lathe anchoring process but I'm sure we'll be in sync after tomorrow - when you come to the site.

As to the tooling purchases - I would pass this on to our parts coordinator - Don Mann. Don purchases all of our tooling now so he would know who our preferred suppliers are. I should be able to Hook you up with Don tomorrow.

Electrical relocation, etc. - we can also cover this tomorrow. Most of our monorails are rated at a minimum of 2 tons so that should be sufficient. I don't think we'll be doing any "major" fabrication on larger items.

I'll plan to see you tomorrow at 2:00 - I'm scheduled for all day tomorrow already but will find a few minutes to get with you. Thanks.

Curtis Hooper
LEXAN Finishing Maintenance Engineer
812/831-7583; Dialcom 8*393-7583; Fax 8*393-7375
curtis.hooper@gepex.ge.com

Date: Wed Nov 26 15:27:22 1997
From: "Hooper, Curtis (GEP)" <Curtis.Hooper@gepex.ge.com>
To: "'kbenedic@comsource.net'" <kbenedic@comsource.net>
Cc: "Conyers, Wayne (GEP)" <Wayne.Conyers@gepex.ge.com>
Subject: RE: Machine shop

Keith, I made a copy of the owners manual for the lathe. I put it on the tailstock on the lathe. Feel free to take it home with you if you want - it is a copy - the original is still in the document center.

Also, I have arranged for Don Mann to meet with us next Tuesday, the 2nd, at 2:30 pm, to discuss the acquisition of tooling.

Have a good holiday weekend - see you on the 2nd!

Curtis Hooper
LEXAN Finishing Maintenance Engineer
812/831-7583; Dialcom 8*393-7583; Fax 8*393-7375
curtis.hooper@gepex.ge.com

Illustration #1: Milling Machine and Storage Racks



Illustration #2: Milling Machine and Storage Racks

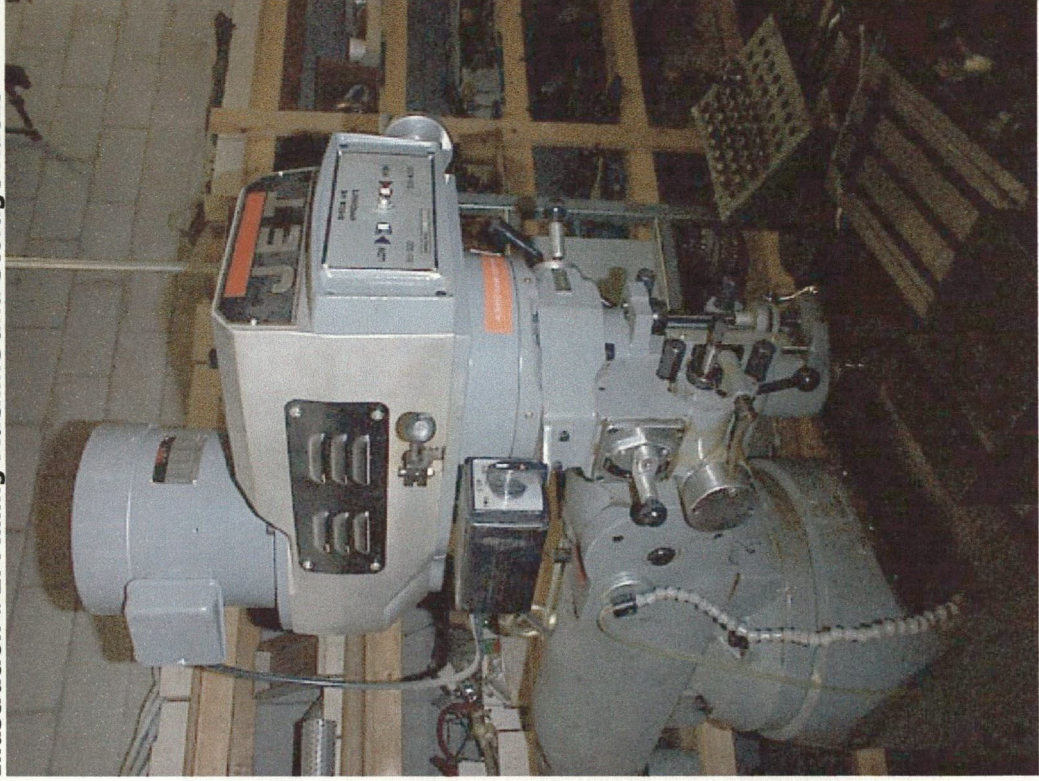

Illustration #3: Milling Machine and Storage Racks

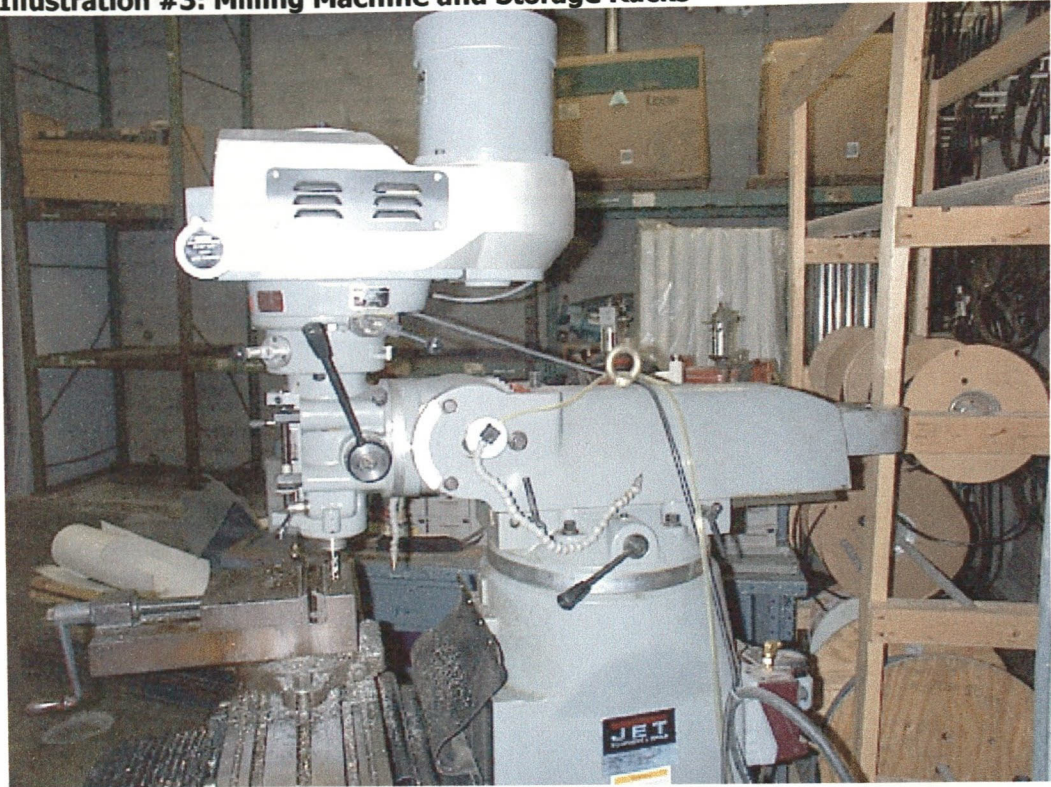

Illustration #4: Engine Lathe & Storage Racks

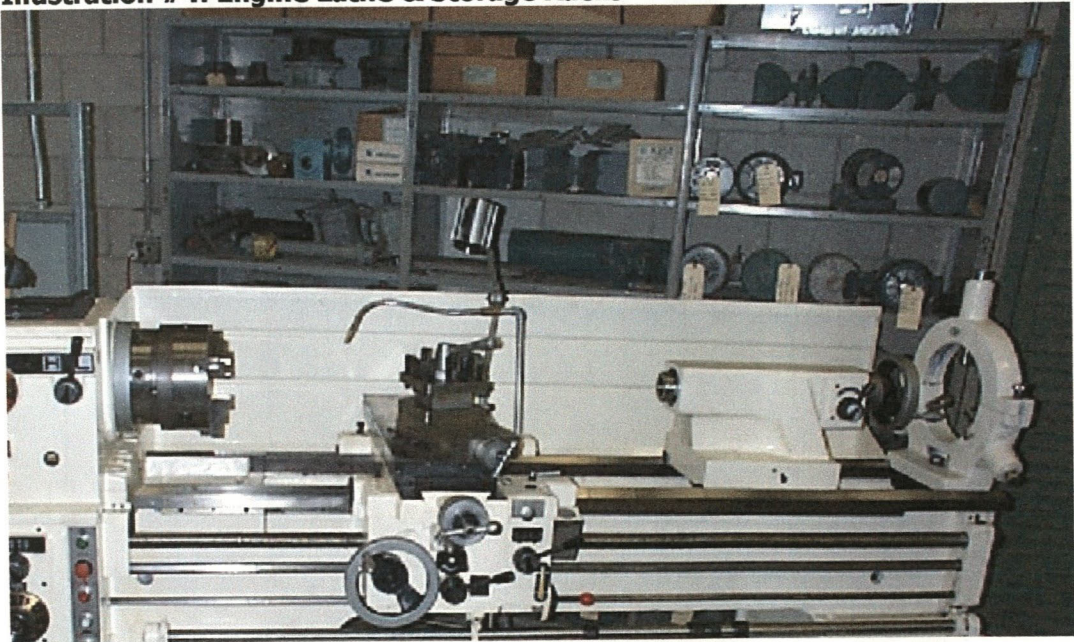

Illustration #5: Original Room Layout

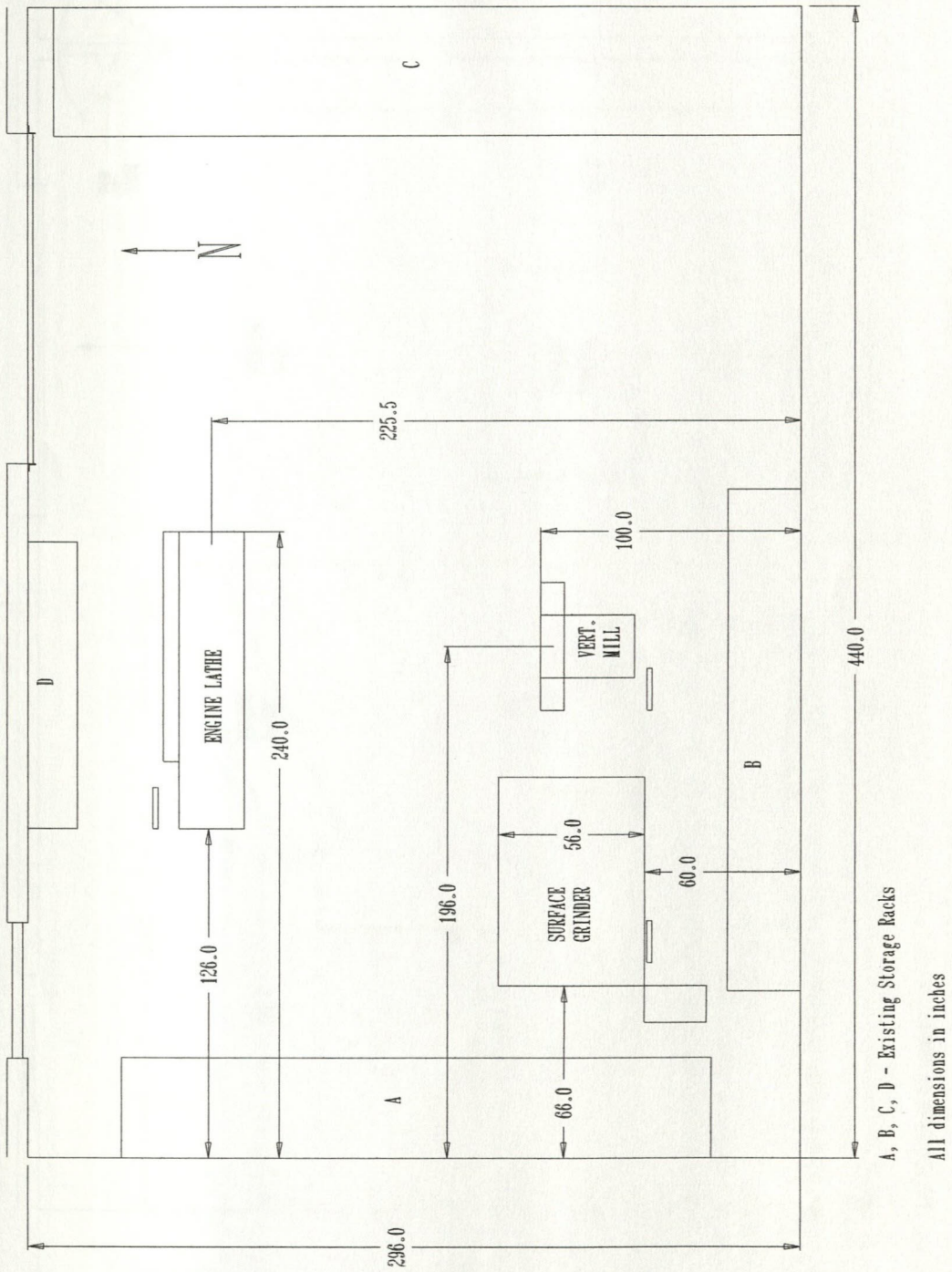
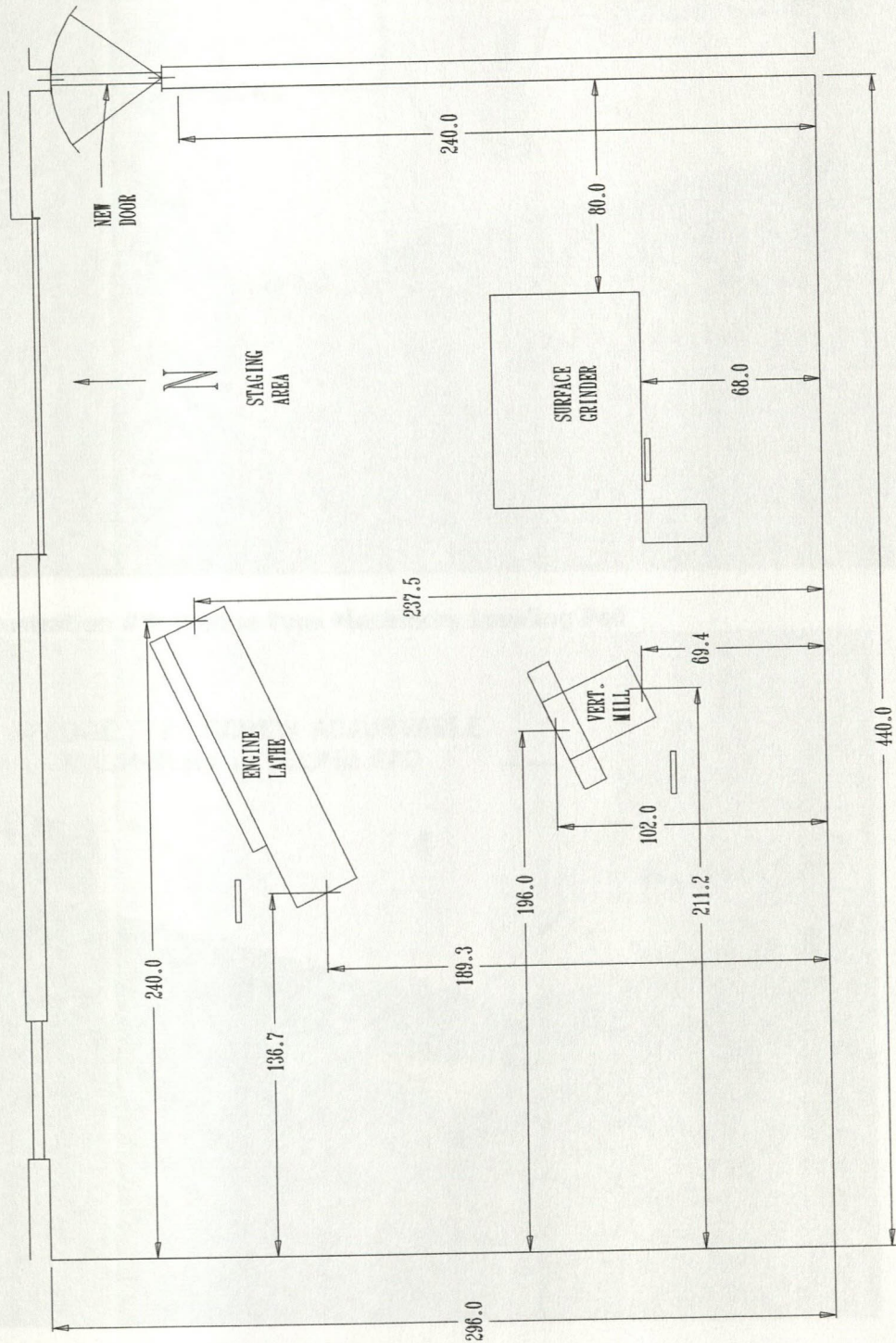

Illustration #6: New Room Layout



All dimensions in inches

Illustration #7: Screw Adjuster and Machinery Leveling Pads

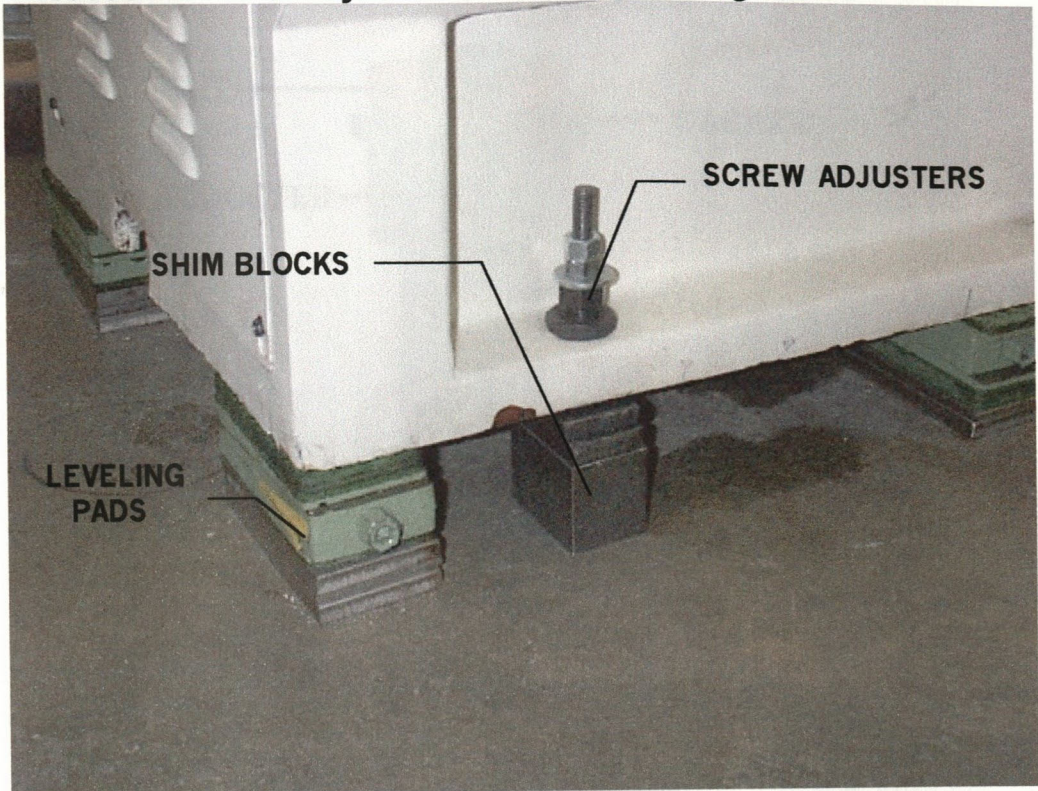

Illustration #8: Wedge Type Machinery Leveling Pad

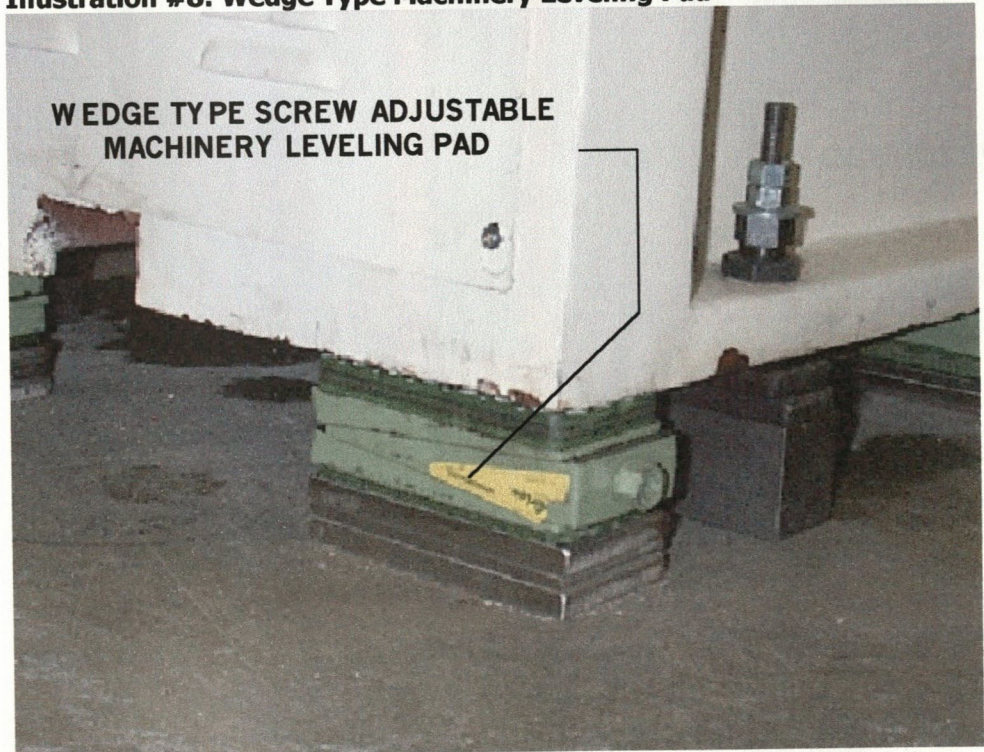
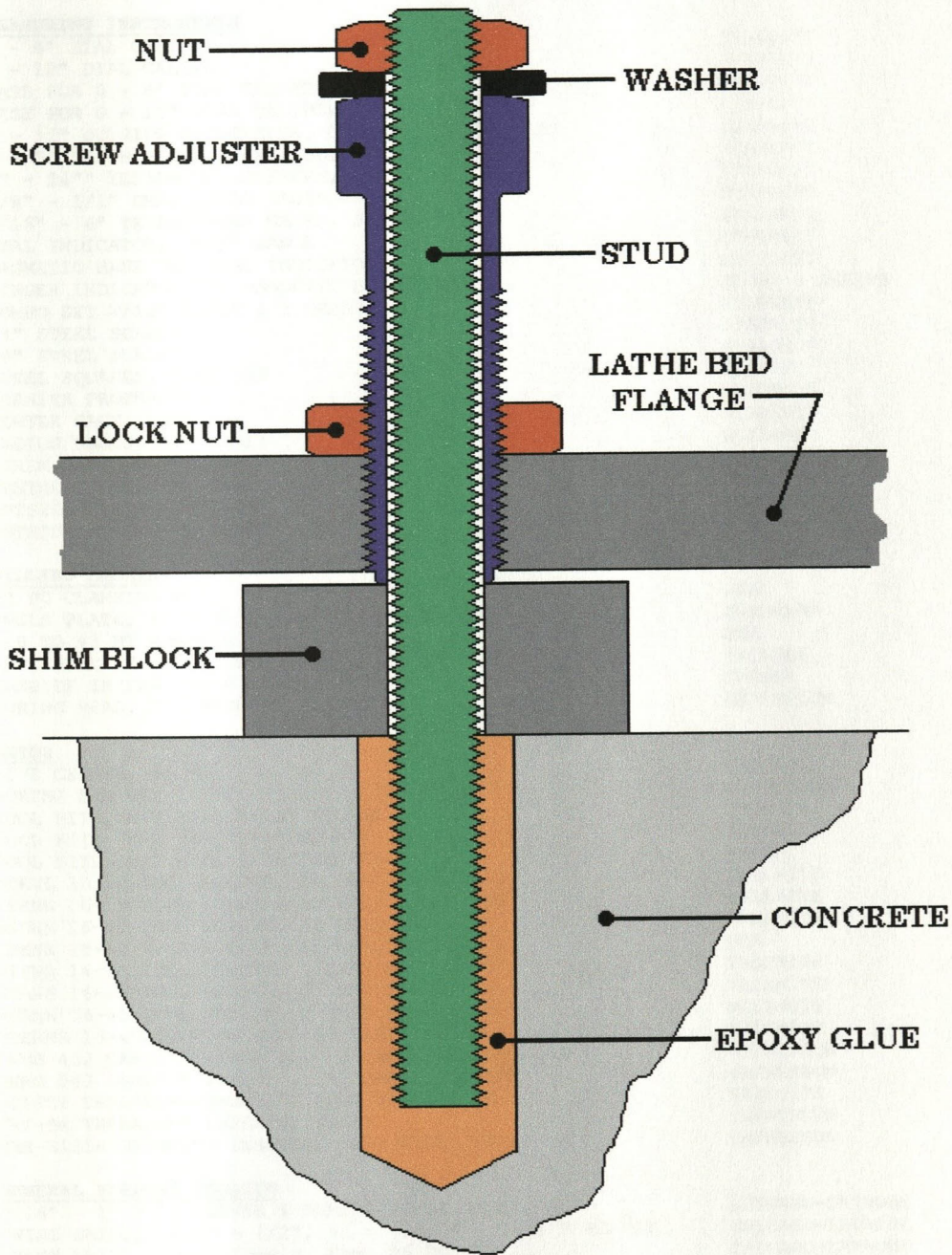

Illustration #9: Cross Section of Floor Anchor and Leveling Screw



Tool Order

ITEM DESCRIPTION	BRAND	QUAN.
MEASURING INSTRUMENTS		
0 - 6" DIAL CALIPER	STARRETT	2
0 - 12" DIAL CALIPER	STARRETT	1
CASE FOR 0 - 6" DIAL CALIPER	STARRETT	2
CASE FOR 0 - 12" DIAL CALIPER	STARRETT	1
0 - 12" OUTSIDE MICROMETER, CARBIDE TIPPED, SET	STARRETT	1
0 - 9" DEPTH MICROMETERS, SET	STARRETT	1
4" - 24" INSIDE MICROMETERS, SET	STARRETT	1
1/8" - 1/2" SMALL HOLE GAGES, SET	STARRETT	1
5/16" - 6" TELESCOPING GAGES, SET	STARRETT	1
DIAL INDICATOR, .500" RANGE	STARRETT	1
MAGNETIC BASE FOR DIAL INDICATOR	STARRETT	1
FINGER INDICATOR AND MAGNETIC BASE, SET	BROWN & SHARPE	1
COMBO SET W/12" SCALE & 3 HEADS	STARRETT	2
24" STEEL SCALE	STARRETT	1
48" STEEL SCALE	STARRETT	1
STEEL SQUARES, 5 PC SET	IMPORT	1
VERNIER PROTRACTOR	MITUTOYO	1
CENTER GAGE, 60	STARRETT	1
RADIUS GAGES, 24 PC SET	GENERAL	1
SCREW PITCH GAGES, SET	STARRETT	1
CENTER FINDER, 5 PC SET	STARRETT	1
OUTSIDE SPRING CALIPERS, 6"	FOWLER	1
OUTSIDE SPRING CALIPERS, 10"	FOWLER	1
MILLING MACHINE		
52 PC CLAMPING KIT	USA	1
ANGLE PLATE, 6" x 5" x 4.5", SLOTTED, WEBBED END	SUBURBAN	2
R-8 TO #3 MT ADAPTER	USA	1
INDEXABLE END MILL SET, R-8 SHANK, 3PC SET	TRI-DEX	1
CARBIDE INSERTS, C-6 GRADE, TPG-322	IMPORT	30
BORING HEAD, 3", W/TOOLS, 12 PC SET	CRITERION	1
LATHE		
LIVE CENTER, #5 MT	ROYAL	1
BORING BAR SET	ARMSTRONG	1
TOOL BITS, M-2 HSS, 3/16" SQUARE	IMPORT	10
TOOL BITS, M-2 HSS, 1/4" SQUARE	IMPORT	10
TOOL BITS, M-2 HSS, 3/16" SQUARE	IMPORT	10
MSRNL 16-5D TOOL HOLDER, 15 LEAD ANGLE, LH	VALENITE	1
MSRNR 16-5D TOOL HOLDER, 15 LEAD ANGLE, RH	VALENITE	1
MSDNN 16-5D TOOL HOLDER, 45 LEAD ANGLE	VALENITE	1
MSKNR 16-5D TOOL HOLDER, 15 LEAD ANGLE	USA	1
MTFNR 16-4D TOOL HOLDER, 0 LEAD ANGLE, RH	VALENITE	1
MTANR 16-4D TOOL HOLDER, 0 LEAD ANGLE, RH	VALENITE	1
MTANR 16-4D TOOL HOLDER, 0 LEAD ANGLE, LH	VALENITE	1
MTENNS 16-4D TOOL HOLDER, 60 LEAD ANGLE	VALENITE	1
TNMG 432 CARBIDE INSERTS, C-6 GRADE, TRIANGULAR	VR/WESSON	30
SNMG 543 CARBIDE INSERTS, C-6 GRADE, SQUARE	VR/WESSON	30
OFFSET THREADING/GROOVING TOOL HOLDER, RH	VALENITE	1
VRT-3R THREADING INSERTS, VR663	VR/WESSON	10
VRG-3125R GROOVING INSERTS, .125 WIDE, VR663	VR/WESSON	5
GENERAL PURPOSE TOOLING		
9/16" - 1" 8 PC SILVER & DEMING STYLE DRILL, SET	CHICAGO-LATROBE	1
TWIST DRILL, 1/16" - 1/2", #1 - #60, A - Z, 115 PC SET	CHICAGO-LATROBE	1
TWIST DRILL, 1mm - 13mm x .5mm, 25 PC SET	CHICAGO-LATROBE	1
TWIST DRILL, 33/64" - 1" x 64THS, MT SHANK, 32 PC SET	IMPORT	1
#1 - #5 CENTER DRILL, PLAIN STYLE, 5 PC SET	CHICAGO-LATROBE	1
CHATTERLESS 82 COUNTERSINKS, 1/4" - 1", 8 PC SET	USA	1
#5 TO #4 MT SLEEVE	COLLIS	1
#4 TO #3 MT SLEEVE	COLLIS	1
#3 TO #2 MT SLEEVE	COLLIS	1
4 FLUTE HSS DOUBLE END MILL, 1/4"	USA	5
4 FLUTE HSS DOUBLE END MILL, 3/8"	USA	5
4 FLUTE HSS DOUBLE END MILL, 1/2"	USA	5
2 FLUTE HSS DOUBLE END MILL, 1/4"	USA	5
2 FLUTE HSS DOUBLE END MILL, 3/8"	USA	5
2 FLUTE HSS DOUBLE END MILL, 1/2"	USA	5
SQUARE TOOL BITS, M2 HSS, 1" SQ	IMPORT	4

**Illustration #10:
Fixed and Adjustable Gauges**



**Illustration #11:
Combination Square Set**

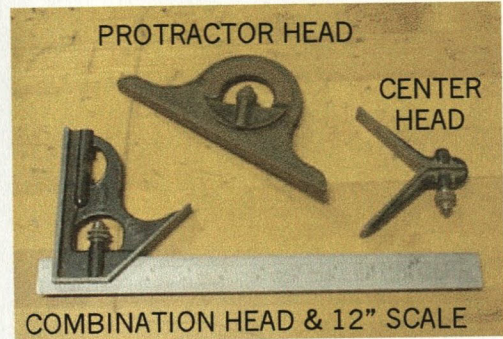

**Illustration #12:
Several Common Precision Measuring Tools**

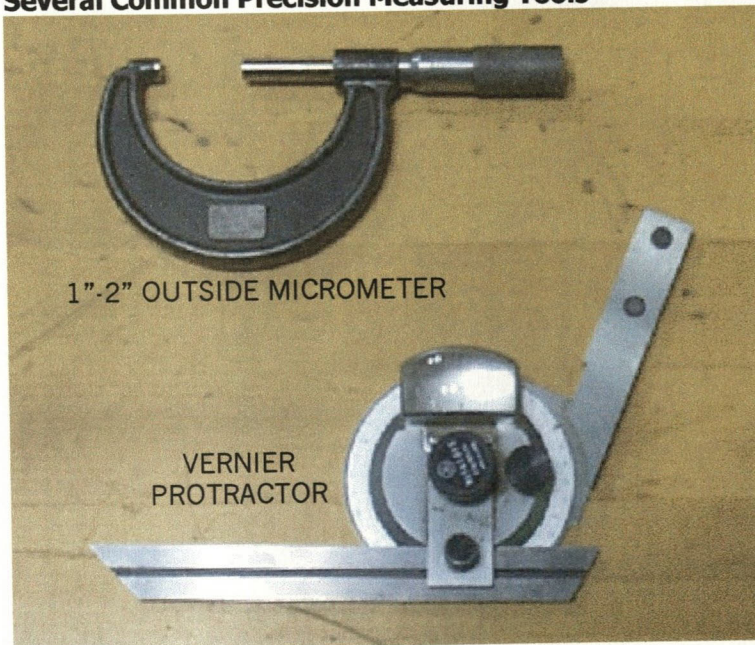

Illustration #13: Lathe Tailstock Centers



**LIVE TAILSTOCK CENTER
(BEARING ALLOWS POINT TO
ROTATE WITH WORKPIECE)**

**DEAD TAILSTOCK CENTER
(NO BEARING - WORKPIECE
ROTATES AROUND POINT)**

Illustration #14: Typical Lathe Operations

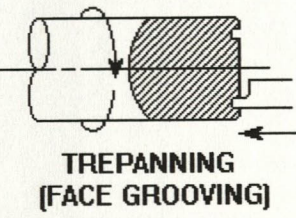
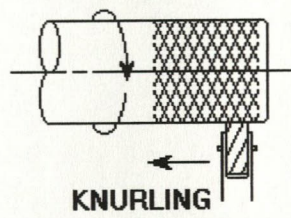
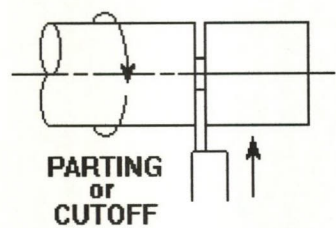
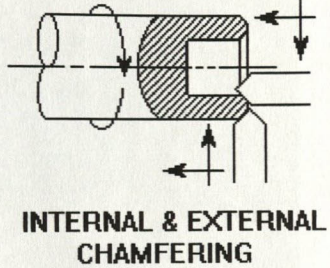
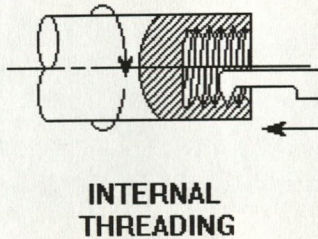
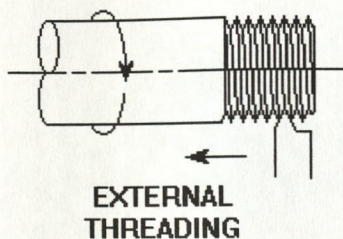
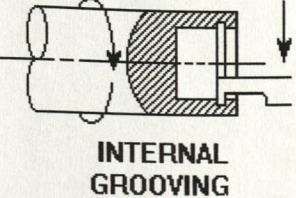
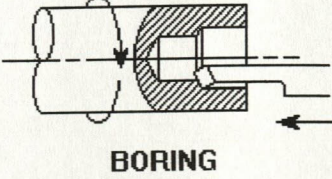
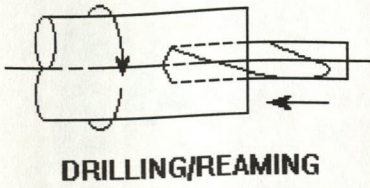
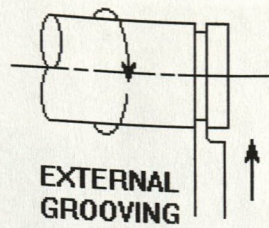
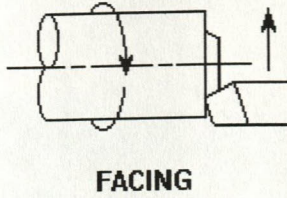
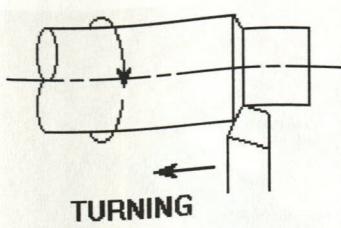

Illustration #15: Typical Negative Rake Lathe Tools and Carbide Insert

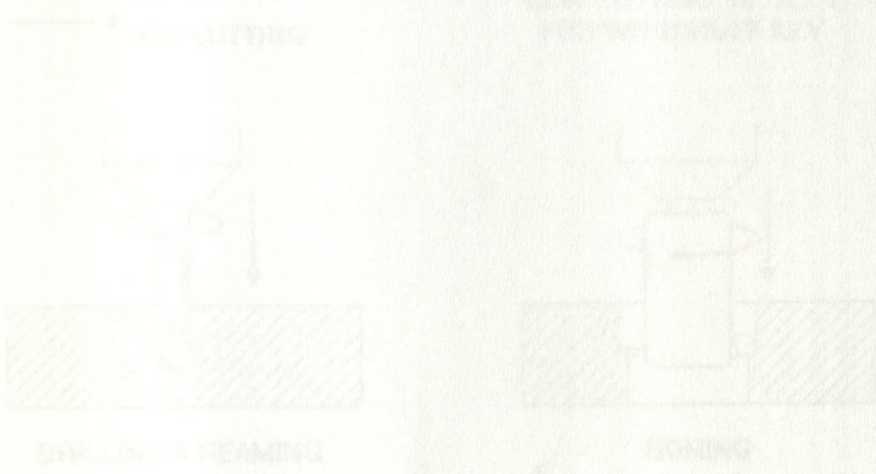
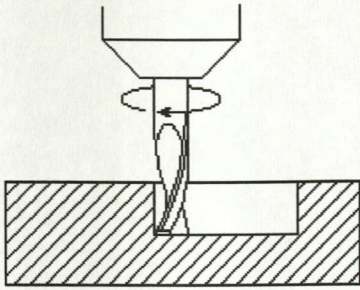
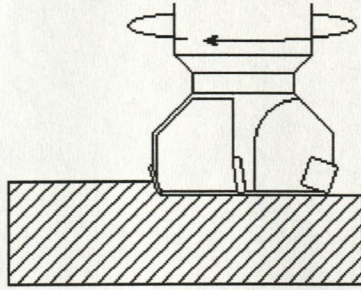

Illustration #16: Typical Milling Machine Operations



END MILLING OF SLOT



SLAB MILLING

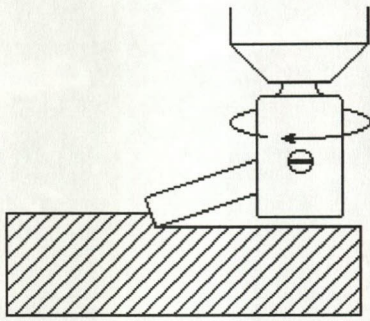

FLY CUTTING

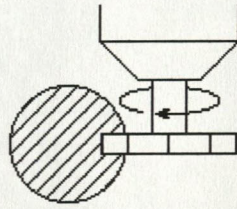

SAW CUTTING OF SLOT FOR WOODRUFF KEY

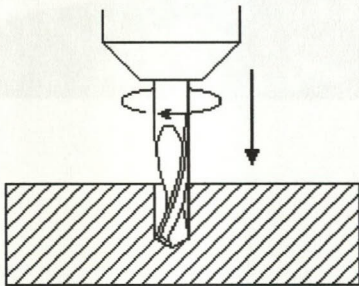

DRILLING & REAMING

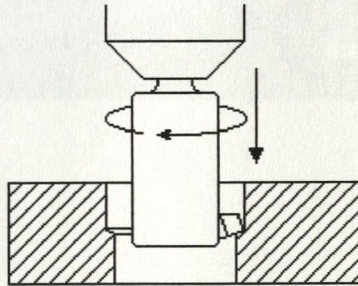

BORING

Illustration #17: Milling Machine Table T-Slots w/T-Nut and Stud

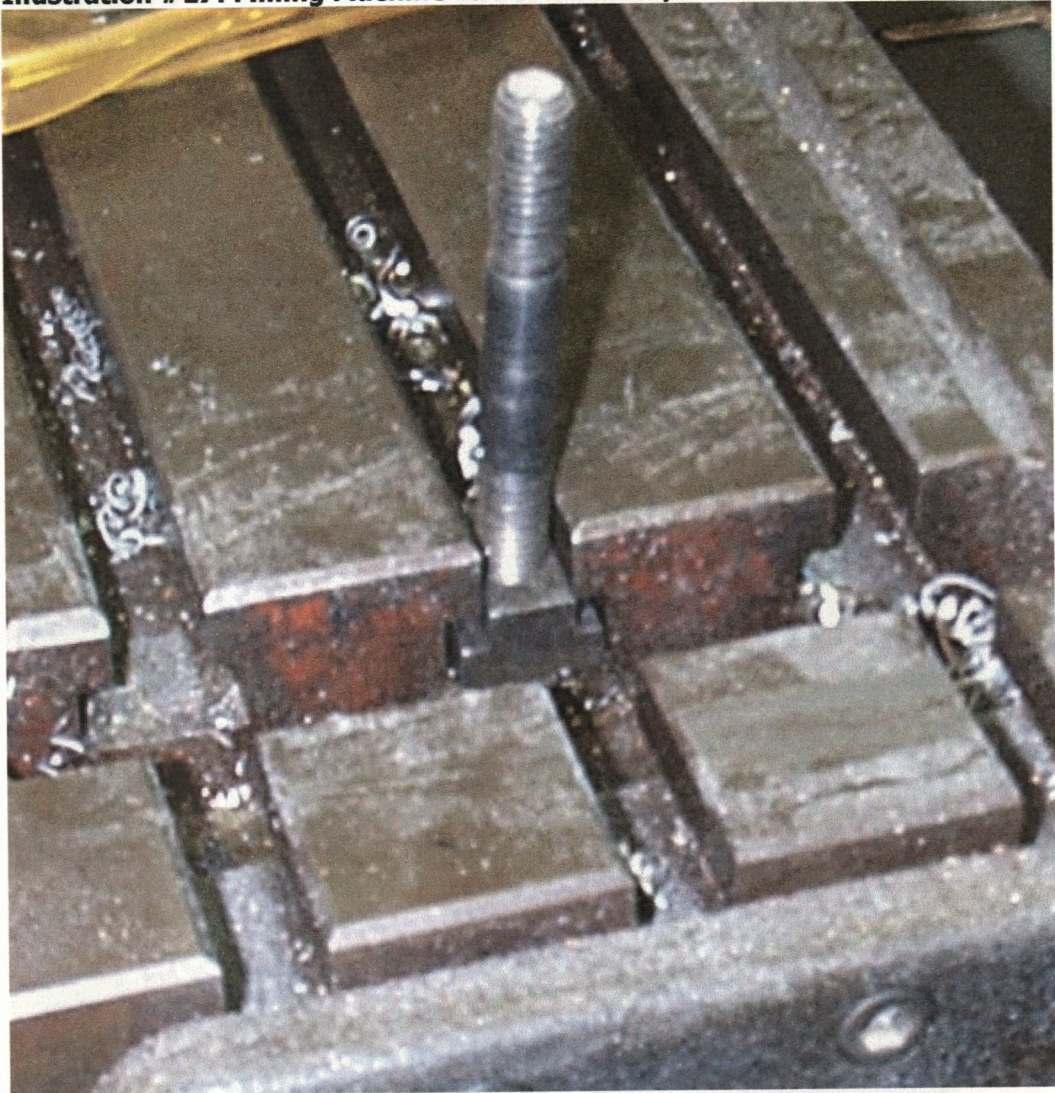

Illustration #18: Various R-8 Shank Tools



Illustration 19: Other Tool Shank Styles



Illustration #20: Opening Screen of MACHINIST'S ASSISTANT program.

(Note that the URL in Navigator's Location field is that of the document that sets up the frames. The URL in the MACHINIST'S ASSISTANT Location frame is that of the document in the lower right frame.)

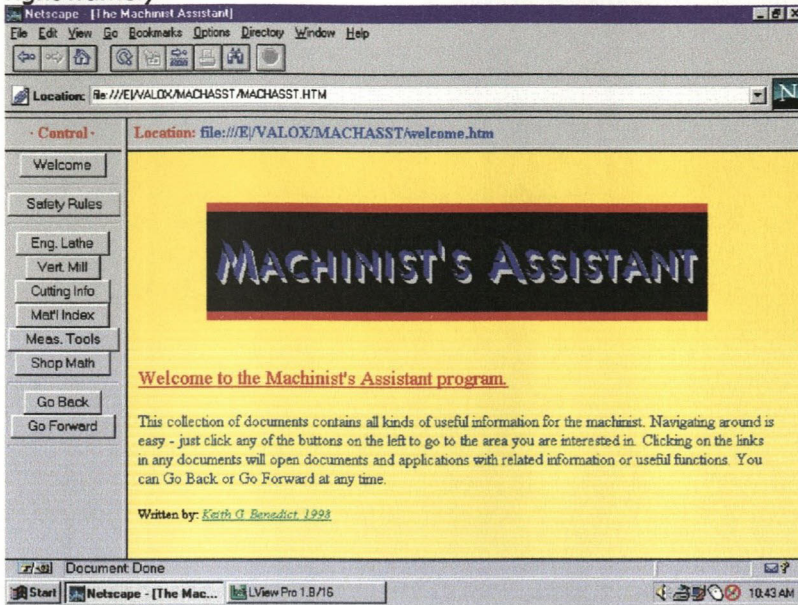
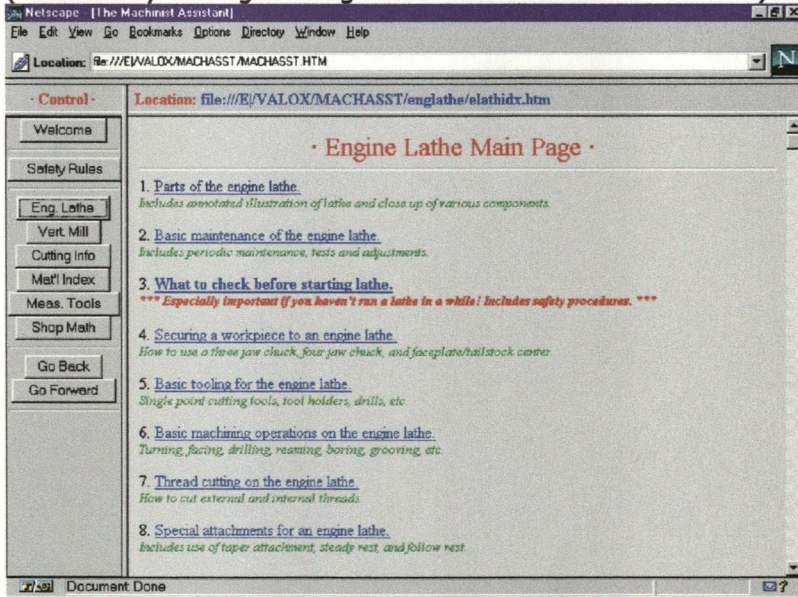

Illustration #21: Main Page of Engine Lathe Section.

(Accessed by clicking on "Eng. Lathe" button in Control column.)



Part VIII: Appendix B - Lesson Plans & Student Handouts

Session #1

Objectives:

- Familiarize students with the course.
- Reinforce students' basic math skills.
- Prepare students to read and follow instructions that used fractional values.
- Acquaint students with concepts of cutting speed and feed rate as applied to lathes and milling machines.
- Acquaint students with concepts of table velocity for milling.
- Teach students how to find and use data relating to cutting speed, etc.
- Teach students how to use math to calculate RPM and table velocity.

Topics

- How to use a calculator.
- Fraction to decimal conversion.
- Cutting speed, feed rate, and table velocity for milling.
- Calculating and using table velocity of milling machines.
- Use of trigonometry in the machine shop.

Handouts

- Fraction to Decimal Conversion Sheet
- Table of Speeds and Feeds
- Formula for RPM Conversion
- Formula for Calculating Milling Table Velocity
- Milling Machine Math Sample Problems #1
- Basic Trigonometry

Comments

- Be sure students sign attendance sheet.

Machinist's Training - Lesson Plan

Session: #1

Objectives

Familiarize students with calculators.

Reinforce student's basic math skills.

Prepare students to read measuring instruments that yield in decimal values.

Acquaint students with concepts of cutting speed and feed rate as applied to lathes and milling machines.

Acquaint students with concepts of table velocity for milling.

Teach students how to find and use data relating to cutting speed, etc.

Teach students how to use data to calculate RPM and table velocity.

Topics

How to use calculator.

Fraction to decimal conversion.

Cutting speed, feed rate, and table velocity for milling.

Calibrating and setting table velocity of milling machine.

Use of trigonometry in the machine shop.

Handouts

Fraction to Decimal Equivalent Sheet

Table of Speeds and Feeds

Formula for RPM Calculation

Formula for Calculating Milling Table Velocity.

Milling Machine Math Sample Problems #1

Basic Trigonometry

Comments

Be sure students sign attendance sheet.

· Fraction to Decimal Equivalent Sheet ·

$1/64 =$

$33/64 =$

$1/32 =$

$17/32 =$

$3/64 =$

$35/64 =$

$1/16 =$

$9/16 =$

$5/64 =$

$37/64 =$

$3/32 =$

$19/32 =$

$7/64 =$

$39/64 =$

$1/8 =$

$5/8 =$

$9/64 =$

$41/64 =$

$5/32 =$

$21/32 =$

$11/64 =$

$43/64 =$

$3/16 =$

$11/16 =$

$13/64 =$

$45/64 =$

$7/32 =$

$23/32 =$

$15/64 =$

$47/64 =$

$1/4 =$

$3/4 =$

$17/64 =$

$49/64 =$

$9/32 =$

$25/32 =$

$19/64 =$

$51/64 =$

$5/16 =$

$13/16 =$

$21/64 =$

$53/64 =$

$11/32 =$

$27/32 =$

$23/64 =$

$55/64 =$

$3/8 =$

$7/8 =$

$25/64 =$

$57/64 =$

$13/32 =$

$29/32 =$

$27/64 =$

$59/64 =$

$7/16 =$

$15/16 =$

$29/64 =$

$61/64 =$

$15/32 =$

$31/32 =$

$31/64 =$

$63/64 =$

$1/2 =$

· Table of Speeds and Feeds ·

Cutting Speeds for High Speed Steel* tooling.

[Note: All speeds are in feet/min].

*Multiply the listed speeds by a factor of 2 to 4 when using carbide tooling.

Material Type	Turning	Drilling	Reaming
Aluminum	400 - 1000	250 - 600	100 - 300
Brass	225 - 300	150 - 300	130 - 200
Bronze	150 - 225	100 - 250	75 - 180
Cast Iron, soft	100 - 150	75 - 150	60 - 100
Cast Iron, medium	75 - 120	70 - 110	35 - 65
Cast Iron, hard	50 - 90	60 - 100	20 - 55
Copper	100 - 200	60 - 100	40 - 60
Magnesium	600 - 1200	300 - 650	150 - 350
Stainless Steel:			
free machining	100 - 150	65 - 100	35 - 85
other grades	40 - 85	15 - 50	15 - 30
Carbon and Alloy Steel:			
free machining	125 - 200	100 - 145	60 - 100
less than 0.3% C	75 - 175	70 - 120	50 - 90
0.3% to 0.6% C	65 - 120	55 - 90	45 - 70
more than 0.6% C	60 - 80	40 - 60	40 - 50
Titanium	25 - 55	30 - 60	10 - 20

Feeds and Speeds for End Milling using High Speed Steel* tooling.

*Multiply the listed speeds by a factor of 2 when using carbide tooling.

Material	Feedrate (in/tooth)		Cutting Speed (ft/min)	
	End Mill Diameter (in)		Roughing	Finishing
	1/4	1		
Aluminum	0.003	0.009	600	800
Bronze, medium	0.003	0.007	250	300
Bronze, hard	0.002	0.005	125	150
Cast Iron, soft	0.003	0.008	60	80
Cast Iron, hard	0.002	0.005	50	70
Plastic	0.003	0.012	150	160
Steel, low C	0.001	0.004	75	90
Steel, 4140	0.0005	0.003	50	70
Steel, 4340	0.0003	0.002	50	70
Stainless Steel:				
Type 304	0.001	0.004	55	75
Type 17-4PH	0.0005	0.003	35	50
Inconel	0.0002	0.003	30	40
Monel-K	0.0003	0.008	60	80
Ti-6Al-4V	0.001	0.004	25	40
Zinc (die castings)	0.002	0.010	800	1000

Feeds* for Drilling

*High Speed Steel and carbide tooling use same values.

<u>Drill Diameter (in)</u>	<u>Drill Feed (in/rev)</u>
Under 1/8	0.001 - 0.003
1/8 to 1/4	0.002 - 0.005
1/4 to 1/2	0.004 - 0.007
1/2 to 1	0.007 - 0.017
Over 1	0.015 - 0.030

Feeds* for Rough** Turning

*High Speed Steel and carbide tooling use same values.

**Feeds for finishing depend on required surface finish. Finer feeds generally give smoother surfaces.

<u>Material</u>	<u>Feedrate (in/rev)</u>
Aluminum	0.007 - 0.050
Cast Iron	0.011 - 0.025
Copper Alloys	0.005 - 0.022
Nickel Alloys	0.005 - 0.018
Stainless Steel***	0.005 - 0.022
Steel	0.010 - 0.090
Titanium	0.007 - 0.018

***The surface of some stainless steels will workharden when cut. A positive feedrate large enough to enable the tool to cut under the affected area is required. Do not allow the tool to apply pressure to workpiece w/o cutting.

Formula for RPM Calculation

The basic equation used to calculate the proper RPM for machining is as follows:

$$\text{RPM} = (\text{cutting speed} \times 12) / (\pi \times \text{diameter})$$

Where the **cutting speed** is in **feet/min** and the **diameter** is in **inches**.

This can be approximated as:

$$\text{RPM} = (3.82 \times \text{cutting speed}) / \text{diameter}$$

In order to use the equation, four pieces of information are required:

1. The workpiece material (steel, cast iron, brass, etc.).
2. The tool material (High Speed Steel, carbide, or ceramic).
3. The type of machining operation to be performed (drilling, milling, turning, etc.).
4. The diameter of the tool or the diameter of the part feature to be machined.

The first three pieces of information allow the machinist to look up the proper cutting speed from a table in *Machinery's Handbook* or other reference source. The fourth piece of information, the diameter, is the largest diameter that the tool "sees", i.e. the diameter of the tool (for drilling and milling) or the diameter of the workpiece feature being machined (turning or boring). An abbreviated [table of speeds and feeds](#) is included here.

rev 1.1 5/27/98

· Formula for Calculating Milling Table Velocity ·

The basic equation used to calculate the proper table velocity for milling is as follows:

$$\text{table velocity} = \text{RPM} \times \text{feedrate} \times N$$

Where **table velocity** is in **in/min** , **RPM** is in **revs/min** , **feedrate** is in **in/tooth** , and **N** is the **number of teeth** on the milling cutter.

In order to use the equation you must first calculate the proper RPM by using the [RPM equation](#). The correct feedrate can be found in various tables in books such as *Machinery's Handbook*. An abbreviated [table of speeds and feeds](#) is included here. The number of cutting teeth must be based on the milling cutter to be used.

In general, the more cutting teeth there are on an milling cutter, the higher the table velocity can be, thus increasing the material removal rate.

rev 1.1 5/27/98

Milling Machine Math Sample Problems #1

Name _____

1. A 3/4" diameter four flute end mill is made of high speed steel. It will be used to cut a slot in a low carbon steel shaft. What RPM should be used? What table velocity should be used?

2. A 2" diameter face mill has three indexible carbide inserts. It can be used at a feedrate of .004 in/tooth when it is used to mill aluminum. What RPM should be used? What table velocity should be used?

3. A 1" diameter two flute high speed steel end mill will be used to cut a slot in a piece of soft cast iron. What RPM should be used? What table velocity should be used?

4. A 3/8" diameter two flute carbide end mill will be used to cut a slot in a nylon wear pad. This type of plastic can be cut at 600 ft/min. The limiting feed rate is based on the roughness of the finished surface; a feedrate no greater than .003 in/tooth must be used to prevent tearing. What RPM should be used? What table velocity should be used?

5. A single tooth carbide tipped flycutter is set to cut a 6" diameter surface. A hard cast iron engine head is to be machined flat. The maximum feedrate is .0015 in/tooth. What RPM should be used? What table velocity should be used?

Basic Trigonometry*

***Trigonometry**, a word derived from Classical Greek, is the branch of mathematics that deals with the **measurement** (*metry*) of closed geometric figures that have **three** (*tri*) **sides** (*gon*).

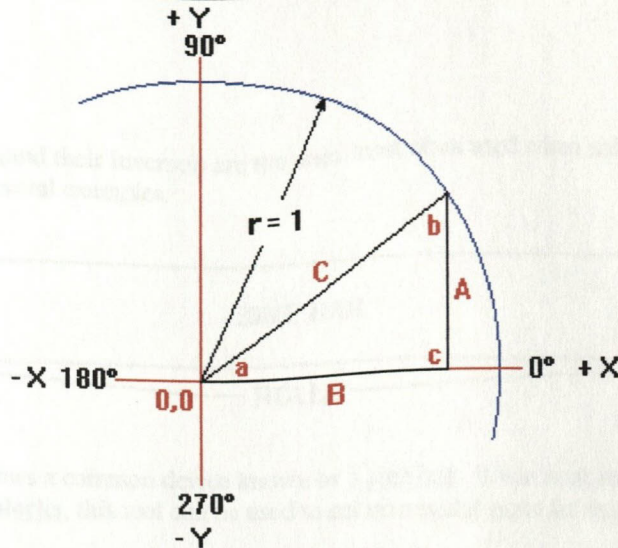

One branch of trigonometry deals with triangles that have one right angle. The illustration above shows a **right triangle** inscribed in a circle that has a **radius** of one (1) unit. The **lengths** of the sides of the triangle are indicated by the capital letters **A**, **B**, and **C**, with side **C** (the **hypotenuse**) being the same length (one unit) as the radius. The interior **angles** of the triangle are indicated with the lower case letters **a**, **b**, and **c**. (Note that the sum of the interior angles of a triangle equal 180 degrees.) The **vertex** of the triangle is located at the center of the circle and is given the co-ordinate value of **X = 0**, **Y = 0**. Standard convention for angular displacement places 0° to the right, with the angle increasing from 0° to 360° in the counter-clockwise direction.

The trigonometric functions **sine** (**sin**), **cosine** (**cos**), **tangent** (**tan**), **secant** (**sec**), **cosecant** (**csc**), and **cotangent** (**cot**) are based on the ratios of two of the sides of the triangle.

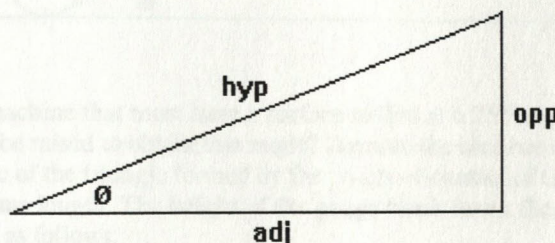

The illustration above shows a **standard triangle**. The sides of the triangle have been relabeled in reference to angle **theta** (θ), where **hyp** is the **hypotenuse**, **opp** is the side **opposite** angle theta, and **adj** is the side **adjacent** to angle theta. The six trigonometric functions are as follows:

1. $\sin \theta = \text{opp/hyp}$
2. $\cos \theta = \text{adj/hyp}$
3. $\tan \theta = \text{opp/adj}$
4. $\sec \theta = \text{hyp/adj}$
5. $\csc \theta = \text{hyp/opp}$
6. $\cot \theta = \text{adj/opp}$

The inverse (or arc) functions of the above are as follows:

1. $\arcsin(\text{opp/hyp}) = \theta$
2. $\arccos(\text{adj/hyp}) = \theta$
3. $\arctan(\text{opp/adj}) = \theta$
4. $\text{arcsec}(\text{hyp/adj}) = \theta$
5. $\text{arccsc}(\text{hyp/opp}) = \theta$
6. $\text{arccot}(\text{adj/opp}) = \theta$

The first three functions (and their inverses) are the ones most often used when solving various shop related problems. Let's look at several examples.

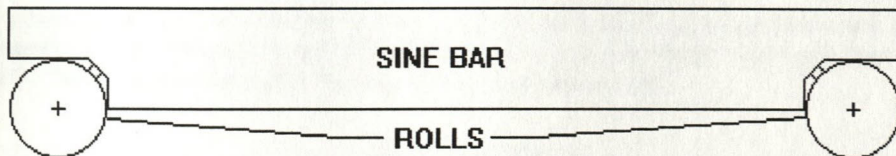

The illustration above shows a common device known as a **sine bar**. When used in conjunction with a set of precision ground **gauge blocks**, this tool can be used to set up angular parts for machining or inspection purposes.

Example #1:

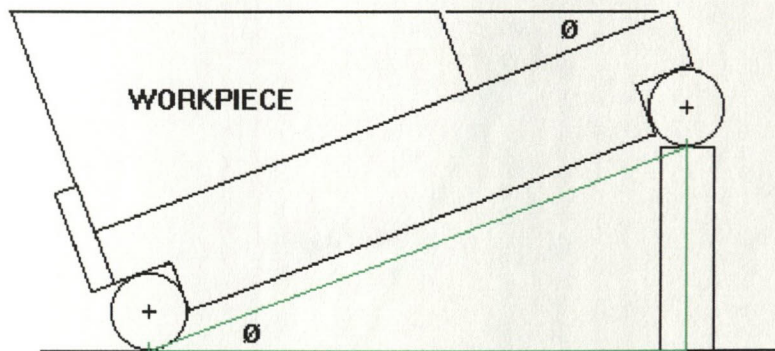

Suppose you have a part to machine that must have a surface milled at a 25° angle to the part's base. How high must one end of the sine bar be raised to obtain this angle? Assume the sine bar measures 8" center-to-center of the two rolls. The hypotenuse of the triangle formed by the points of contact of the rolls with the table surface and the gauge block is the same length. The **height** of the gauge block forms the side of the triangle **opposite** angle theta and can be found as follows:

$$\sin(\theta) = \text{opp/hyp}$$

By using algebra, this can be rearranged as shown here:

$$\text{hyp} \times \sin(\theta) = \text{opp}$$

$$8.000" \times \sin(25^\circ) = \text{opp}$$

$$8.000" \times .4226 = 3.381$$

Example #2:

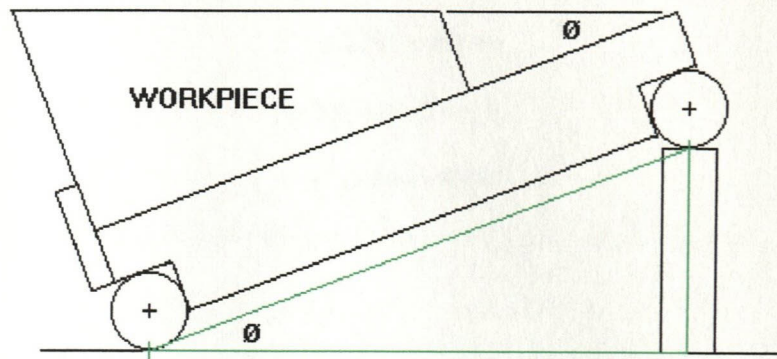

Assume the same sine bar is used to inspect a triangular part. One end is raised up until a dial indicator shows that the top surface of the workpiece is parallel to the table surface. The gauge blocks are checked and found to measure 4.792". What angle is formed? This can be found as shown here:

$$\arcsin(\text{opp/hyp}) = \theta$$

$$\arcsin(4.792/8.000) = \theta$$

$$\arcsin .599 = 36.8^\circ$$

Example #3

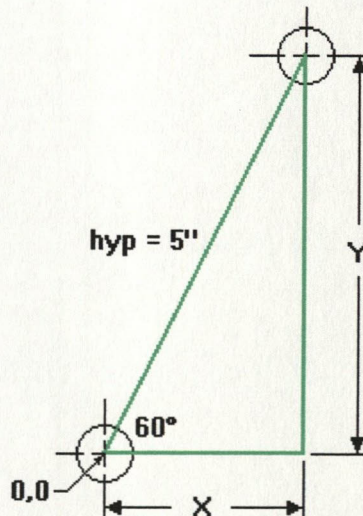

Assume a hole must be drilled at a distance of 5" and at an angle of 60° from an existing hole. The existing hole is given the X,Y coordinates of 0,0. The adjacent side of the triangle formed is the X coordinate, while the opposite side is the Y coordinate. The coordinates of the new hole can be found as follows:

$$\cos 60^\circ = X/\text{hyp}$$

$$\text{hyp} \times \cos 60^\circ = X$$

$$5" \times .500 = 2.500$$

and

$$\sin 60^\circ = Y/hyp$$

$$hyp \times \sin 60^\circ = Y$$

$$5" \times .866 = 4.330$$

Machinist's Training - Lesson Plan

Session: #2

Objectives

Reinforce student's skills in reading micrometers and vernier scales.

Familiarize students with machine shop safety rules.

Acquaint students with the components and controls of the vertical milling machine in their particular shop.

Reinforce the concepts and the application of shop trigonometry by using the milling machine to drill a bolt circle.

Topics

Reading micrometers and verniers

Shop safety

Parts of the vertical mill

Using trigonometry

Using the vertical milling machine to perform precision drilling operations

How to set spindle speed (RPM) and direction of rotation

How to change tools in spindle by using drawbar

Handouts

Machine Shop Safety Rules

How to Read an Inch-Based Micrometer

Micrometer Reading Practice Sheet #1

How to Read an Inch-Based Vernier Scale

Vernier Reading Practice Sheet #1

1.1. Left Side of Vertical Mill *

1.2. Right Side of Vertical Mill *

1.3. Left Side of Knee of Vertical Mill *

1.4. Power Table Feed of Vertical Mill *

*Use handouts appropriate to each functional area

Comments

Be sure students sign attendance sheet.

· Machine Shop Safety Rules ·

1. Eye protection should be worn in the shop at all times. Other safety equipment may be required under certain circumstances.
 2. Never wear gloves while operating machine shop equipment.
 3. Never operate machinery with damaged, broken, or missing guards, brakes, or other safety equipment.
 4. Never disable any guards or safety features on any equipment.
 5. The edges of cutting tools are sharp - do not use excessive force or directly grasp the cutting edge(s) of a tool when changing or adjusting it.
 6. Do not strike hardened materials together. Use soft face (plastic, brass, rubber) hammers wherever possible.
 7. Do not wear rings, loose sleeves, neckties, dangling jewelry, or loose long hair when operating machinery.
 8. Before using any equipment, be sure you know how to use all the controls to operate it safely. If you are unsure about the function of any control or safety device it is **your responsibility** to read any available material or ask for help from more experienced machinists.
 9. Because of the possibility of personal injury from flying particles, and to prevent chips from being blown under the wiper seals of bedways and bearings, the use of compressed air in the shop should be extremely limited. Machines should be cleaned of chips by using brushes or vacuum methods.
 10. Keep your hands away from rotating or reciprocating machine elements, such as drill and lathe chucks, when they are in motion.
 11. Before turning on the spindle of any machine, make sure that all parts and tools are secured properly and that all chuck or drawbar wrenches are removed.
 12. Do not distract or startle the operator of any machine, especially when the machine is under power.
 13. Shop areas should be kept clean and neat. Aisleways should be unobstructed to prevent tripping/falling injuries.
 14. If a lathe chuck, tool, or part is too heavy to handle easily, lifting equipment or additional help should be utilized.
 15. Proper lockout/tagout procedures should be followed when performing maintenance or making most machine adjustments.
-

· How to Read an Inch-Based Micrometer ·

Reading an inch-based micrometer by using the four-step addition method explained here is a relatively easy process. The first set of instructions applies to micrometer movements used on outside and inside micrometers. The second set of instructions applies to depth micrometers.

Basic Micrometer Movement

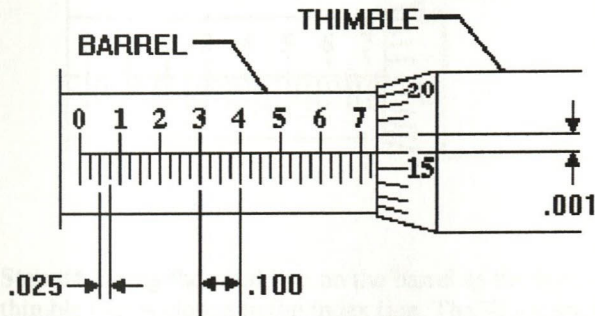

The illustration above shows a basic micrometer movement as used on **outside** and **inside** micrometers. The **thimble** rotates relative to the **barrel** on a threaded shaft that has 40 threads per inch. Therefore one complete revolution of the thimble moves it axially 1/40th, or .025 inch. The **barrel scale** is divided into increments of .025 inch, with each .100 inch numbered for convenience. The **thimble scale** is divided into increments of .001 inch, with each .005 inch numbered around the thimble as 0, 5, 10, 15, and 20.

The following example is presented to illustrate the four-step addition method. To read the indicated value, proceed as follows:

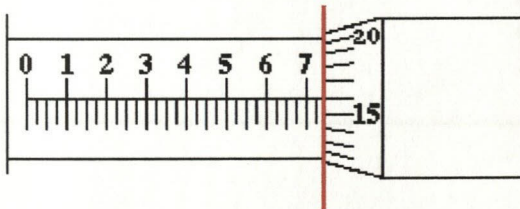

Step #1. Record the whole number that represents the minimum size the micrometer could read. Assume the illustration above is on a 3- to 4-inch outside or inside micrometer. Write it down as shown here:

3.000

Step #2: Using the end of the thimble as an index line, record the whole number of .100 inch increments to the left of the index line. The illustration above shows that there are seven .100 inch increments to the left of the index line, which equals .700 inch. Record this value as shown:

3.000
0.700

Step #3: Still using the end of the thimble as an index line, record the whole number of .025 inch increment to the left of the index line. The illustration above shows that there is one .025 inch increments to the left of the index line, which equals .025 inch. Record this value as shown:

3.000
0.700
0.025

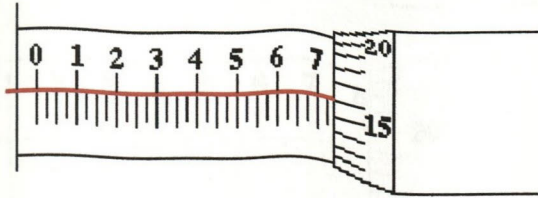

Step #4. Using the axial line on the barrel as the index line, read the number of the .001 increment from the thimble that is closest to the index line. The illustration above shows that there the mark representing sixteen lines up with the index line, which equals .016 inch. Write it down as shown here:

3.000
0.700
0.025
0.016

Now add up the four digits to obtain the correct reading:

3.000
0.700
0.025
0.016
3.741

Micrometer Reading Practice Sheet #1

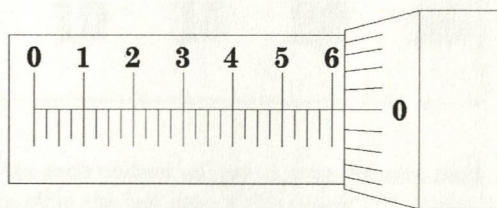
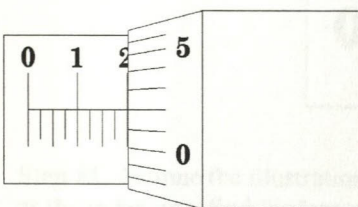
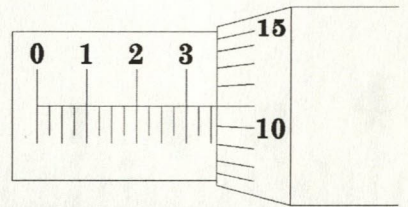
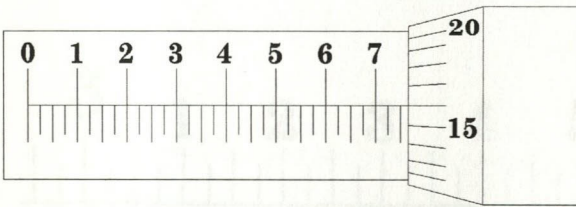
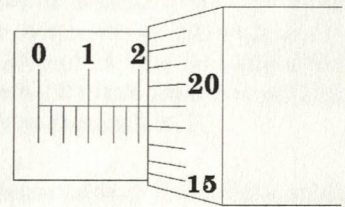
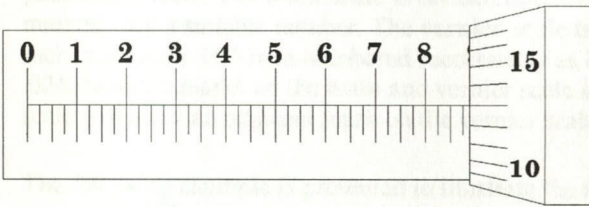
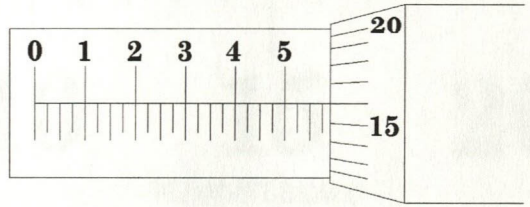
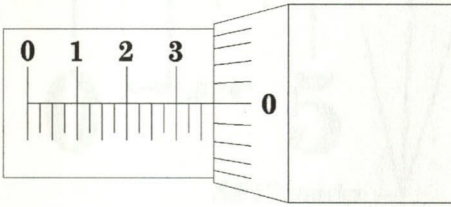
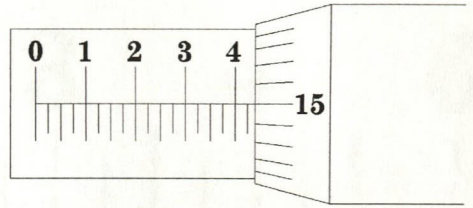
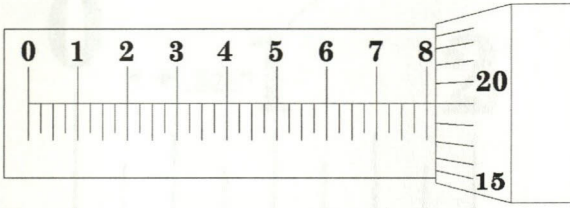
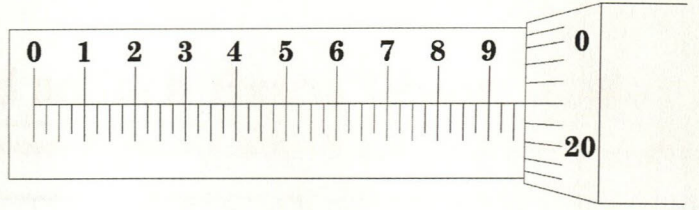
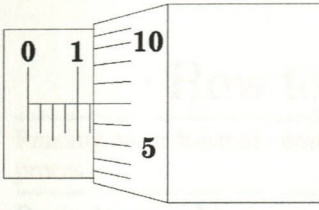

· How to Read an Inch-Based Vernier Scale ·

Reading an inch-based vernier scale by using the four-step addition method explained here is a relatively easy process.

Basic Vernier Movement

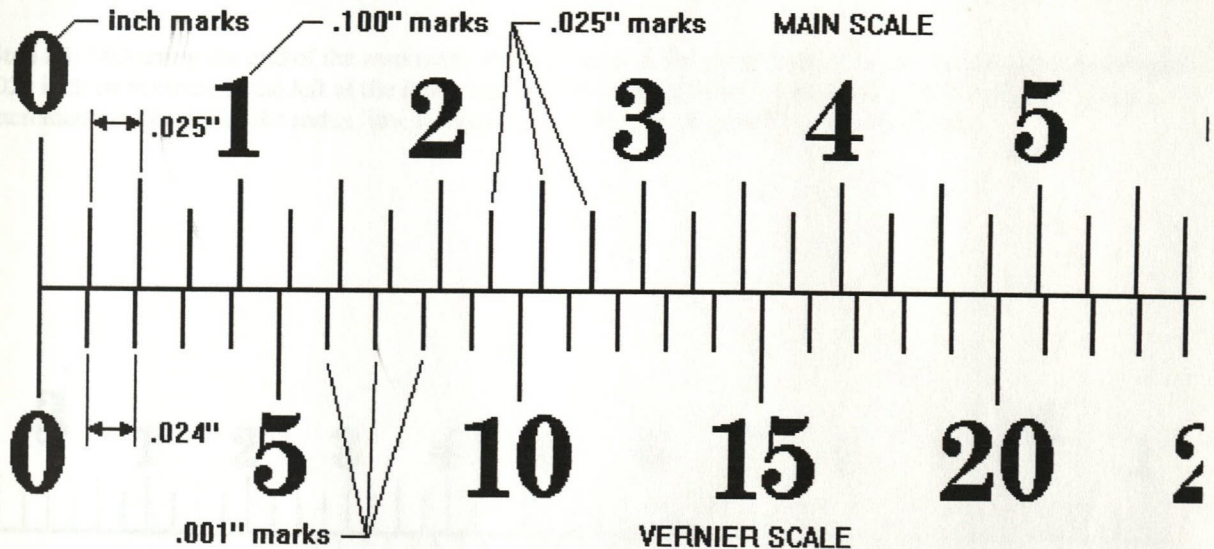

The illustration above shows a basic **vernier movement** as used on vernier calipers and other measuring and positioning tools. The **main scale** is divided into .025 inch increments, with inch and .100 inch increments marked with a suitable number. The **vernier scale** is divided into increments of .024 inch that represent .001 inch, with each .005 inch numbered successively as 0, 5, 10, 15, 20, and 25. The .001 inch difference (.025 - .024) between marks on the main and vernier scale means that each .001 inch change in position of the vernier scale will align an adjacent mark on the vernier scale with a mark on the main scale.

The following example is presented to illustrate the four-step addition method. To read the indicated value, proceed as follows:

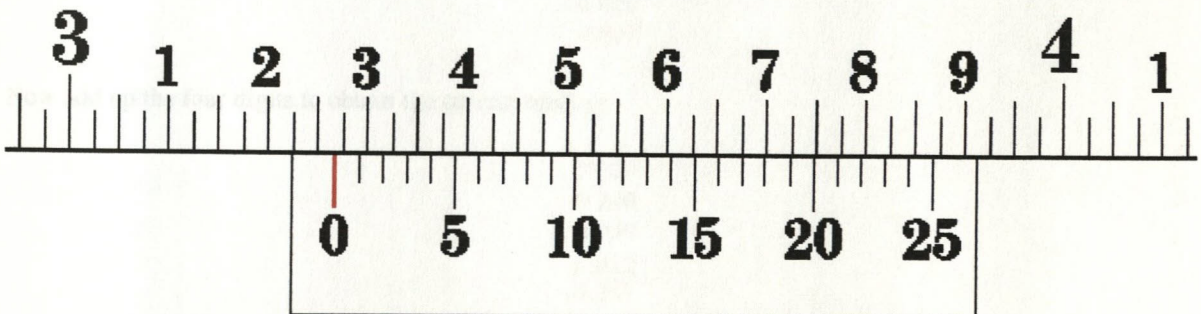

Step #1. Assume the illustration above is of a six-inch vernier caliper. Using the zero mark on the vernier scale as the index line, find the largest whole inch mark to the left side of this index line. Write it down as shown here:

3.000

Step #2: Still using the end of the zero mark on the vernier scale as the index line, find the largest .100 inch mark to the left side of this index line. The illustration above shows that there are two .100 inch increments to the left of the index line, which equals .200 inch. Record this value as shown:

3.000
0.200

Step #3: Still using the end of the zero mark on the vernier scale as the index line, record the whole number of .025 inch increments to the left of the index line. The illustration above shows that there are two .025 inch increments to the left of the index line, which equals .050 inch. Record this value as shown:

3.000
0.200
0.050

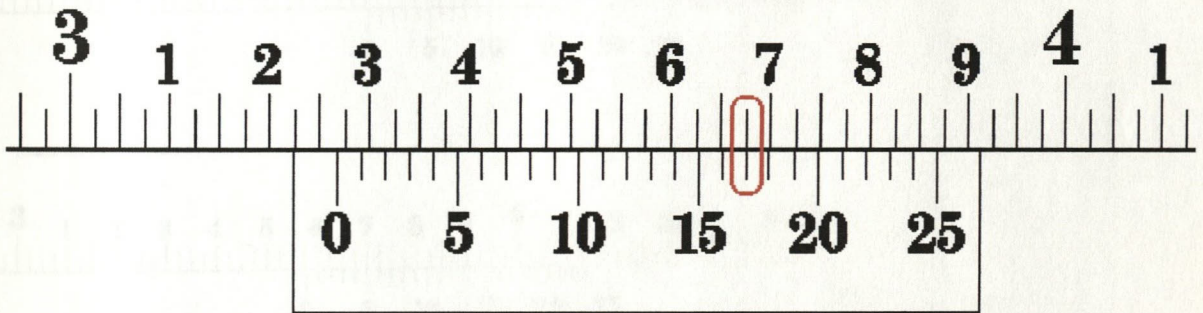

Step #4. In order to obtain a reading to the thousandths of an inch, the vernier scale is now used. Ignore the numbers on the main beam; scan down the vernier scale until you find a line on the vernier scale that lines up with any of the lines on the main beam. The illustration shows that the mark representing 17 (.017 inch) lines up exactly with a mark on the main scale. Write it down as shown here:

3.000
0.200
0.050
0.017

Now add up the four digits to obtain the correct reading:

3.000
0.200
0.050
0.017
3.267

Vernier Reading Practice Sheet #1

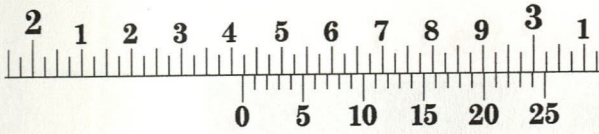

1. _____

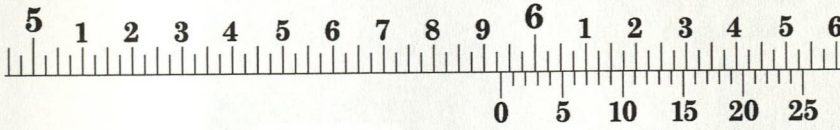

2. _____

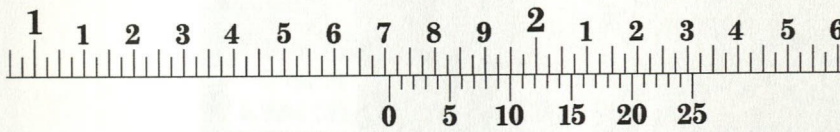

3. _____

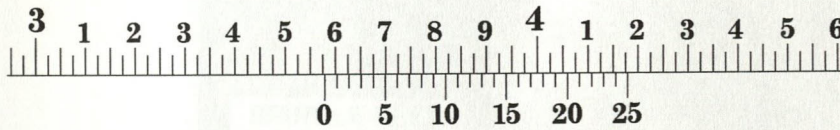

4. _____

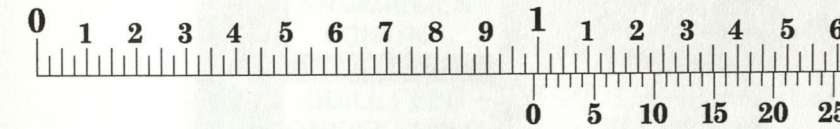

5. _____

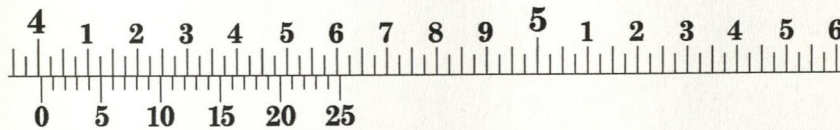

6. _____

· 1.1. Left Side of Vertical Mill ·

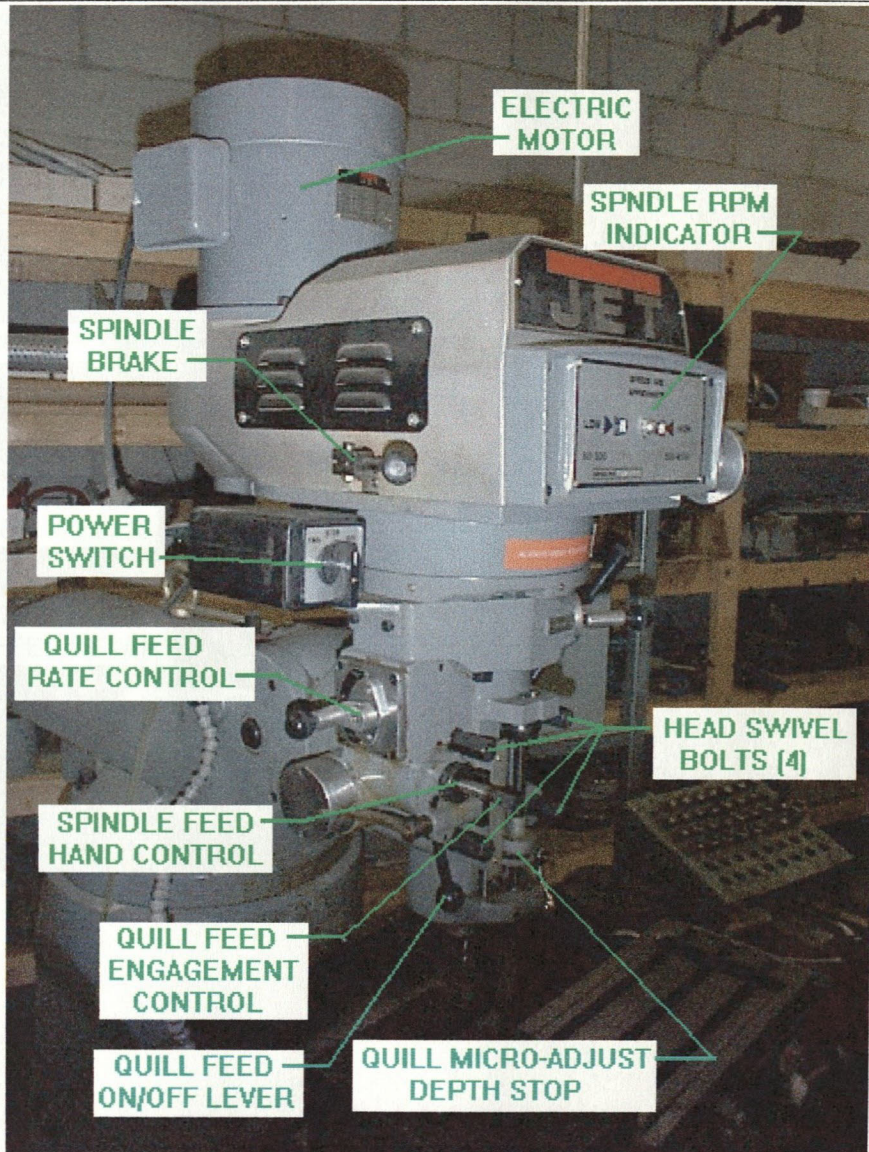

· 1.2. Right Side of Vertical Mill ·

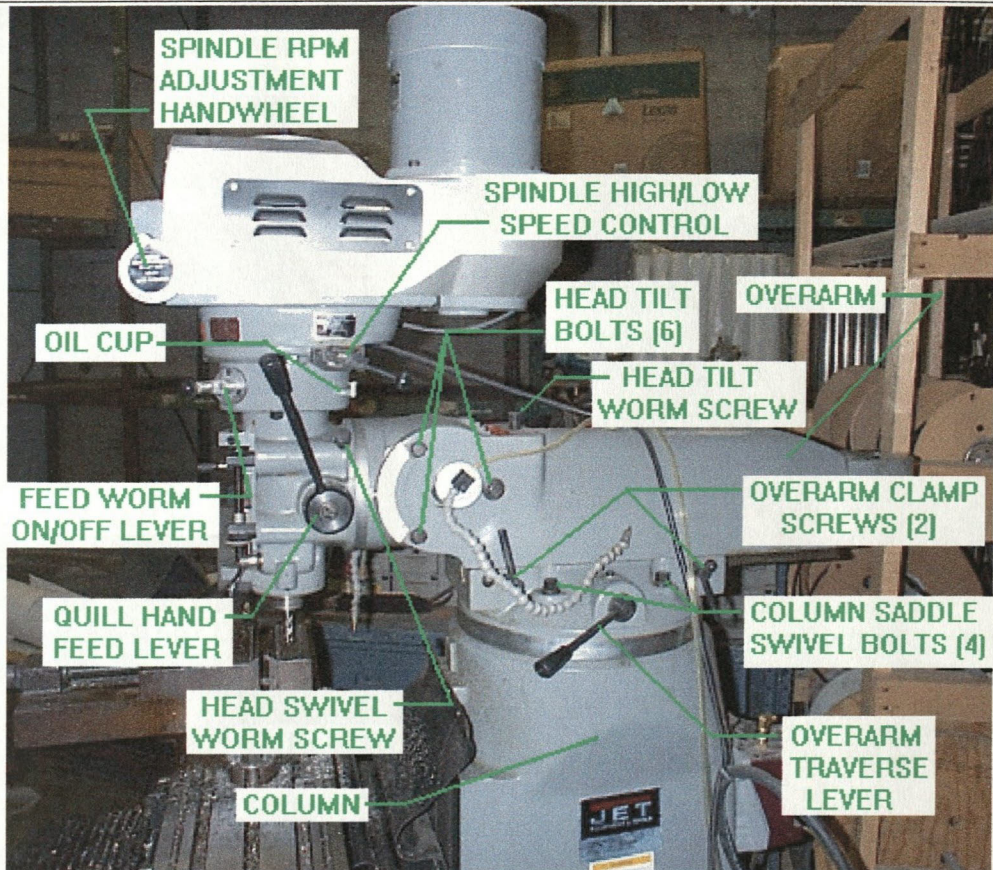

· 1.3. Left Side of Knee of Vertical Mill ·

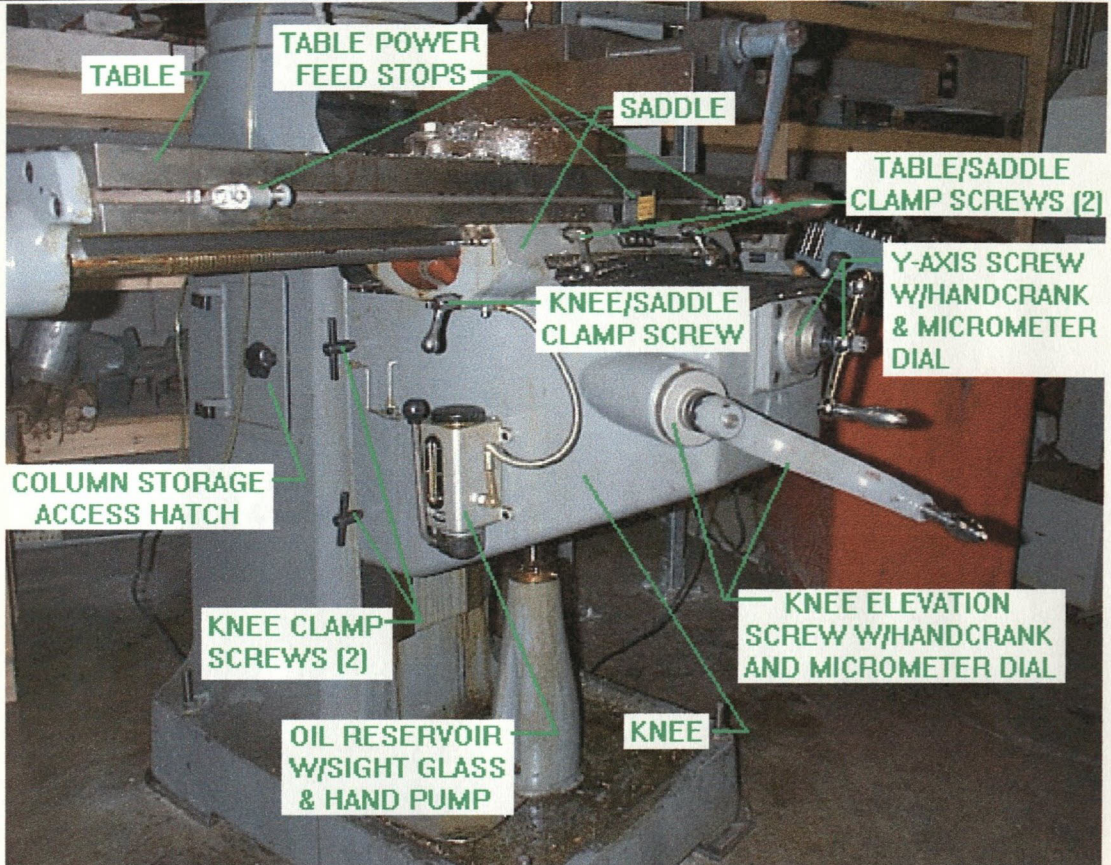

· 1.4. Power Table Feed of Vertical Mill ·

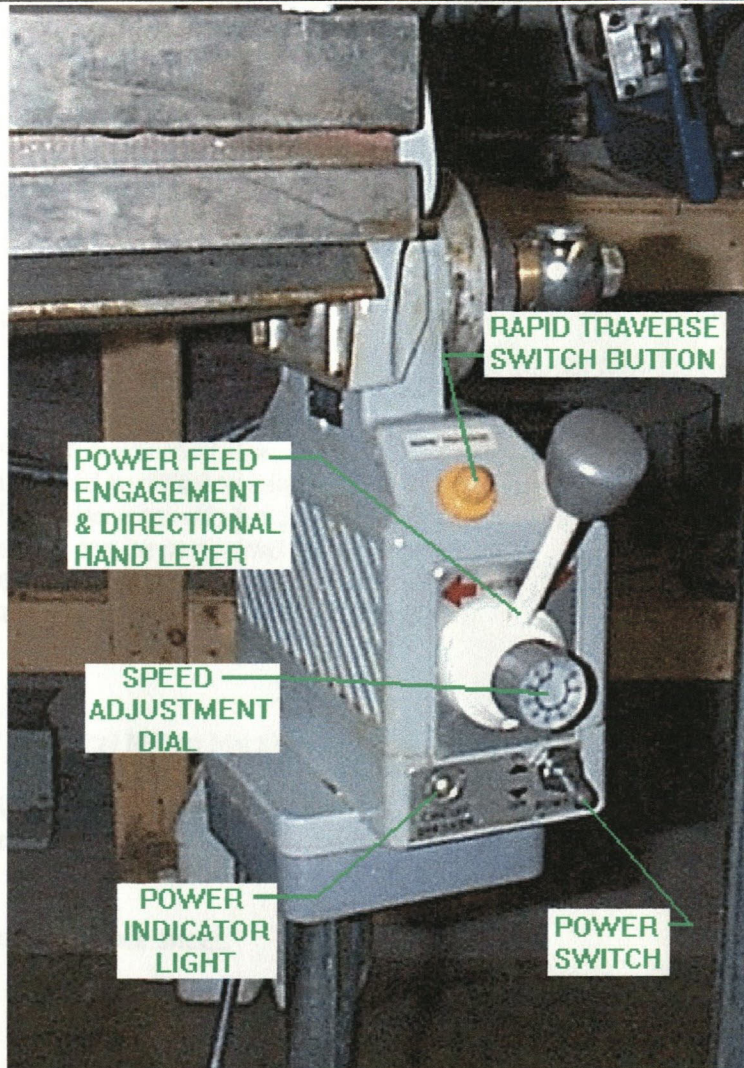

Machinist's Training - Lesson Plan

Session: #3

Objectives

Familiarize students with the parts of a typical center finder set.

Familiarize students with a finger-type indicator.

Have students learn to use a center finder set and finger indicator to align the mill head spindle axis perpendicular to the table top to within 0.001" per 8" of sweep.

Have students learn to use a center finder set and finger indicator to align vise jaw to within 0.001" end-to-end.

Have students learn the different types of machining operations that can be performed on a vertical milling machine.

Have students learn how to properly perform a simple end-milling operation.

Topics

Using center finder set and finger indicator.

How to adjust machine head to different orientations, including perpendicular to table top.

Aligning fixed jaw of machine vise with X-axis of table movement.

Machining operations that can be performed on vertical mill.

Calculating the proper RPM and table velocity for an end-milling operation.

Effects of RPM and table velocity variations on chip and tool.

Handouts

Center Finder Set

Aligning the Head of a Vertical Milling Machine

Milling Machine Vise

Vertical Milling Machine Operations

Angle Plates for Milling Machine

Comments

Be sure students sign attendance sheet.

With one universal ball check, secured in the mill head spindle, locate the ball check against the vertical end of the needle point shaft. Tighten the ball check to the spindle (the ball check is part of spindle). Turn on the spindle in an RPM of 100 to 1500. In slow forward table feed, align the ball check with the point with a small amount of wood, wax, or plastic with the power of the spindle in the air.

NOTE: SAFETY GLASSES AND APPROPRIATE PROTECTIVE CLOTHING SHOULD BE WORN WITH ALL OPERATIONS PERFORMED ON THE MACHINE.

· Center Finder Set ·

What is a center finder set?

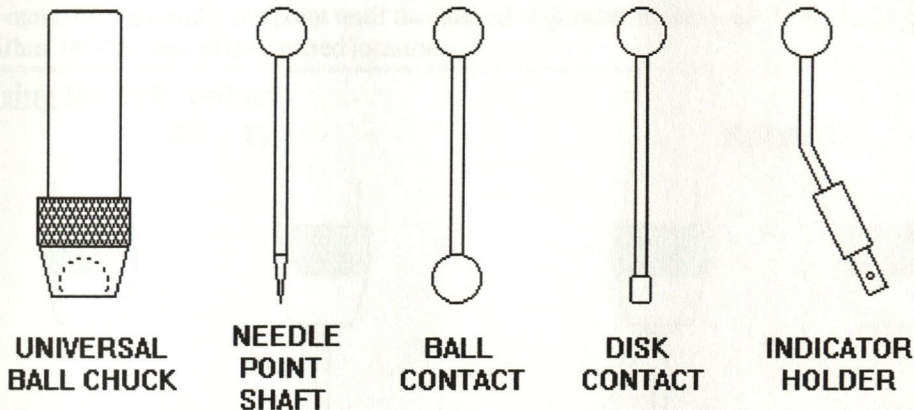

The illustration above shows a typical center finder set consisting of five basic pieces:

1. A universal ball chuck
2. A needle point shaft
3. A disk (or drum) contact
4. A ball contact
5. A dial or finger indicator holder

The universal ball chuck is normally held in a milling machine in a regular adjustable drill chuck or an appropriately sized collet. Any of the other four pieces are then held in the universal ball chuck.

Using the needle point shaft.

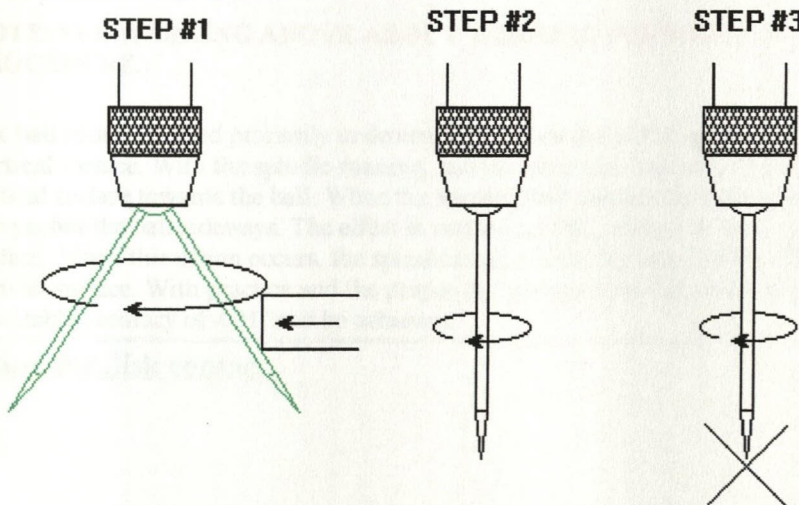

With the universal ball chuck secured in the milling machine spindle, loosen the ball chuck enough to snap in the spherical end of the needle point shaft. Tighten the ball chuck by hand to a moderate tightness (do not use a pair of pliers!). Turn on the spindle to an RPM of 200 to 1000. To align the point, press lightly against the shaft near the point with a small piece of wood, metal, or plastic until the point appears to be frozen in one spot.

NOTE: SAFETY GLASSES AND ANY OTHER REQUIRED PERSONAL PROTECTIVE EQUIPMENT SHOULD BE WORN WHILE PERFORMING THIS PROCEDURE. IF THE NEEDLE

POINT SHAFT POPS OUT OF THE BALL CHUCK AT HIGH RPM IT COULD CAUSE A SERIOUS INJURY!

The needle point shaft is used primarily for lining up the milling machine spindle with a scribed line or punch mark. Raise the knee and/or lower the spindle until it is close to the part surface. Use the table axis handwheels to move the part under the point until the desired alignment is achieved. If done carefully, it is possible to get within .005" or less of the desired location.

Using the ball contact.

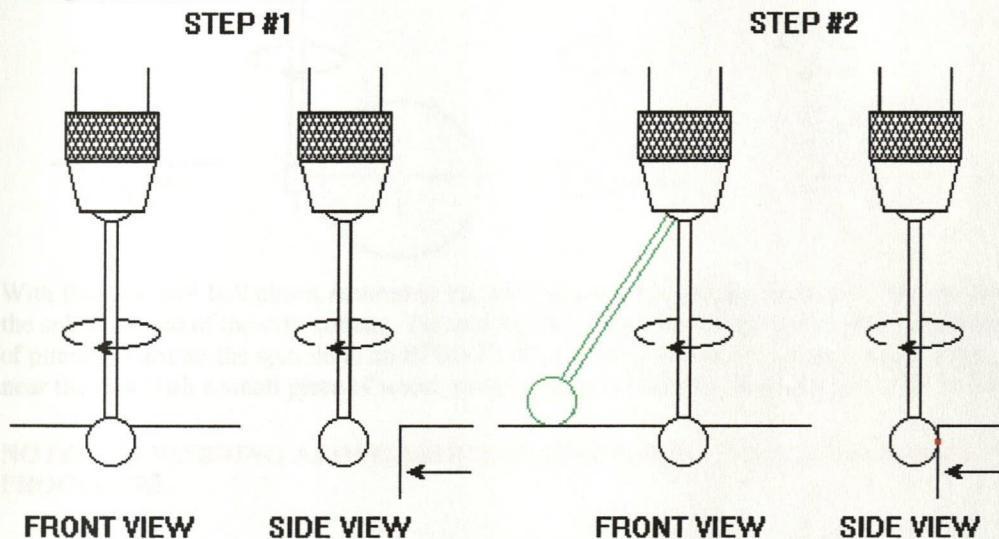

With the universal ball chuck secured in the milling machine spindle, loosen the ball chuck enough to snap in the spherical end of the ball contact. Tighten the ball chuck by hand to a moderate tightness (do not use a pair of pliers!). Turn on the spindle to an RPM of 200 to 1000. To align the point, press lightly against the shaft near the ball with a small piece of wood, metal, or plastic until the ball appears to be frozen in one spot.

NOTE: SEE WARNING ABOVE ABOUT WEARING PPE WHILE PERFORMING THIS PROCEDURE.

The ball contact is used primarily to determine the location of the spindle in relationship to the edge of a **flat vertical surface**. With the spindle running, use the table axis handwheels to slowly and carefully move the vertical surface towards the ball. When the rotating ball touches the vertical surface the friction between the two pushes the ball sideways. The effect is very noticeable, as the ball will attempt to "crawl up" the vertical surface. When this action occurs, the spindle center is exactly one-half the ball diameter from the edge of the vertical surface. With practice and the proper tightening of the ball chuck to give a consistent tension, a repeatable accuracy of .001" can be achieved.

Using the disk contact.

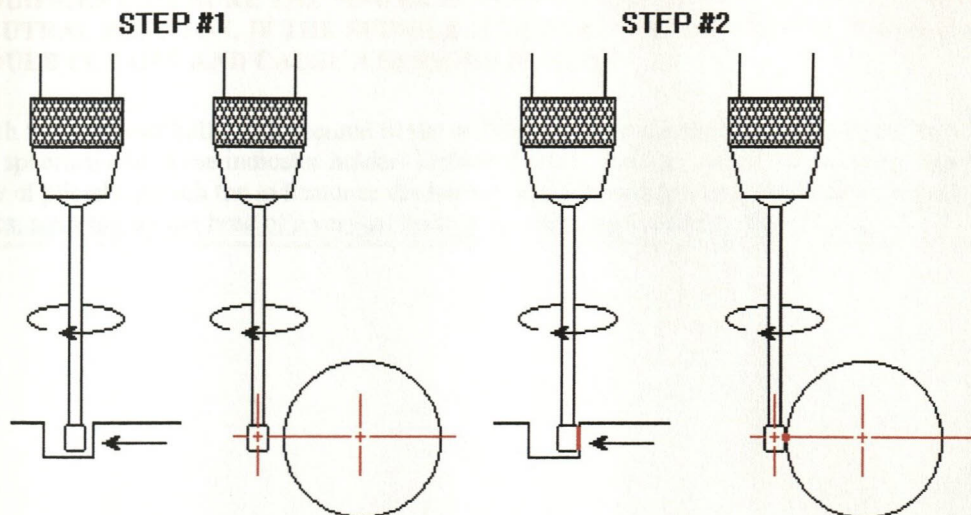

With the universal ball chuck secured in the milling machine spindle, loosen the ball chuck enough to snap in the spherical end of the disk contact. Tighten the ball chuck by hand to a moderate tightness (do not use a pair of pliers!). Turn on the spindle to an RPM of 200 to 1000. To align the point, press lightly against the shaft near the disk with a small piece of wood, metal, or plastic until the disk appears to be frozen in one spot.

NOTE: SEE WARNING ABOVE ABOUT WEARING PPE WHILE PERFORMING THIS PROCEDURE.

The disk contact is used primarily to determine the location of the spindle in relationship to the edge of a **shallow flat vertical surface** or the edge of a **cylindrical surface**. When finding the edge of a cylindrical surface, the height of the midpoint of the disk should be adjusted to be level with center of cylindrical surface. With the spindle running, use the table axis handwheels to slowly and carefully move the surface towards the disk. When the rotating disk touches the surface the friction between the two pushes the disk sideways. The effect is very noticeable, as the disk will attempt to "crawl up" the surface. When this action occurs, the spindle center is exactly one-half the disk diameter from the edge of the surface. With practice and the proper tightening of the ball chuck to give a consistent tension, a repeatable accuracy of .001" can be achieved.

Using the indicator holder.

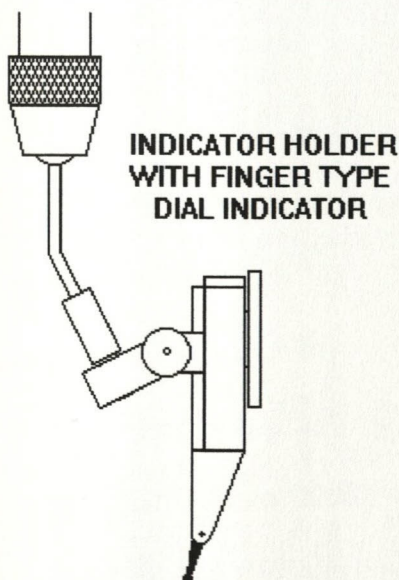

SAFETY NOTE: WHEN PERFORMING ANY PROCEDURE USING THE FOLLOWING

EQUIPMENT, BE SURE THE POWER IS TURNED OFF OR THE SPINDLE IS LOCKED IN THE NEUTRAL POSITION. IF THE SPINDLE IS TURNED ON THE INDICATOR AND HOLDER COULD FLY OFF AND CAUSE A SERIOUS INJURY!

With the universal ball chuck secured in the milling machine spindle, loosen the ball chuck enough to snap in the spherical end of the indicator holder. Tighten the ball chuck by hand to a moderate tightness (do not use a pair of pliers!). Attach the indicator to the holder. Various uses for this combination of tools includes lining up vises, squaring up the head of a vertical milling machine, and locating the center of a hole.

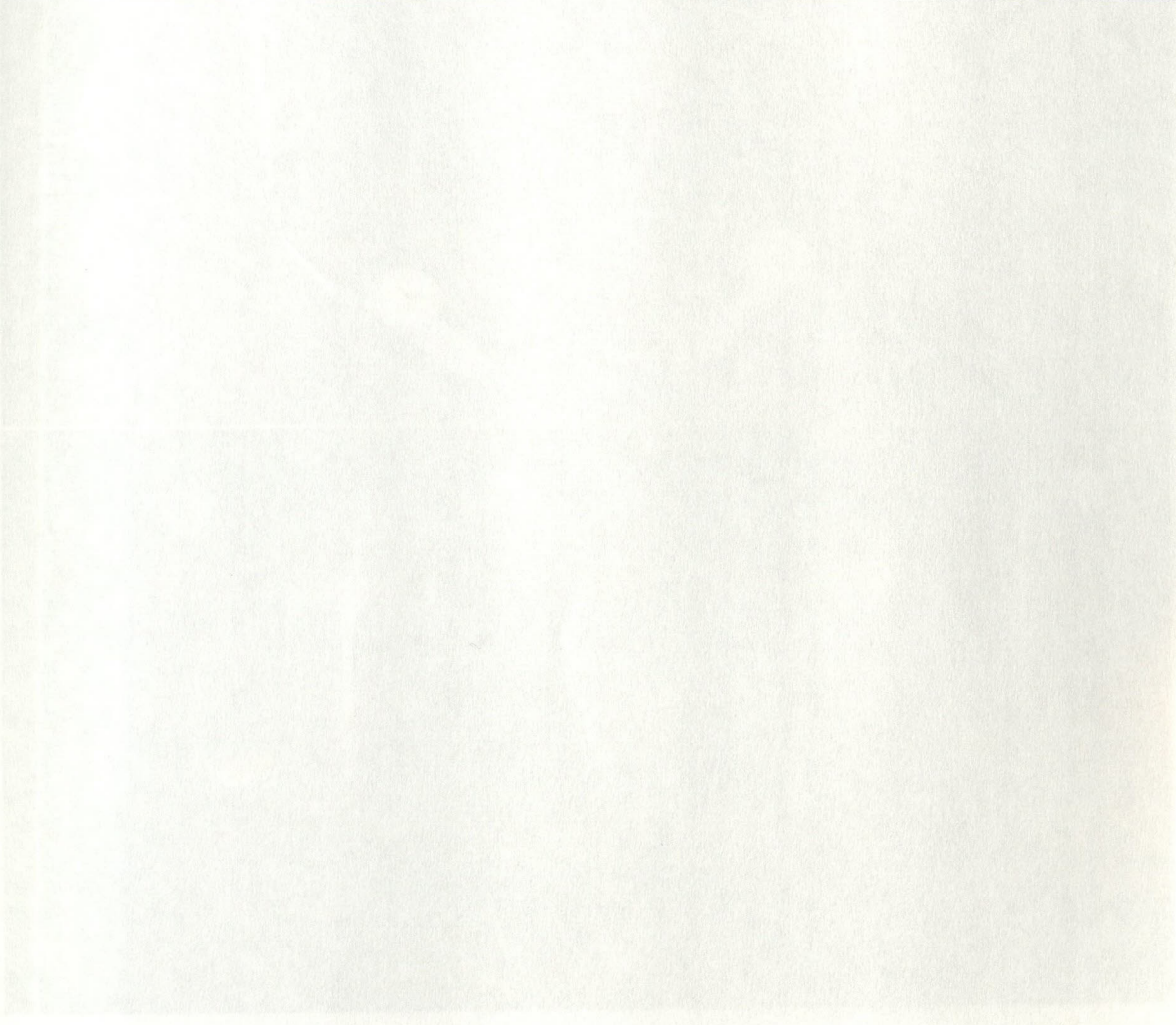

In order to align the head of the milling machine perpendicular to the work surface, a center finder set with a finger indicator can be used. The following instructions describe the location of the center. Now how to do this.

1. Put the spindle gear drive in the neutral position.
2. Secure the universal ball chuck in the end chuck.
3. Secure the indicator holder in the ball chuck.
4. Attach the finger indicator to the holder.

Aligning the Head of a Vertical Milling Machine

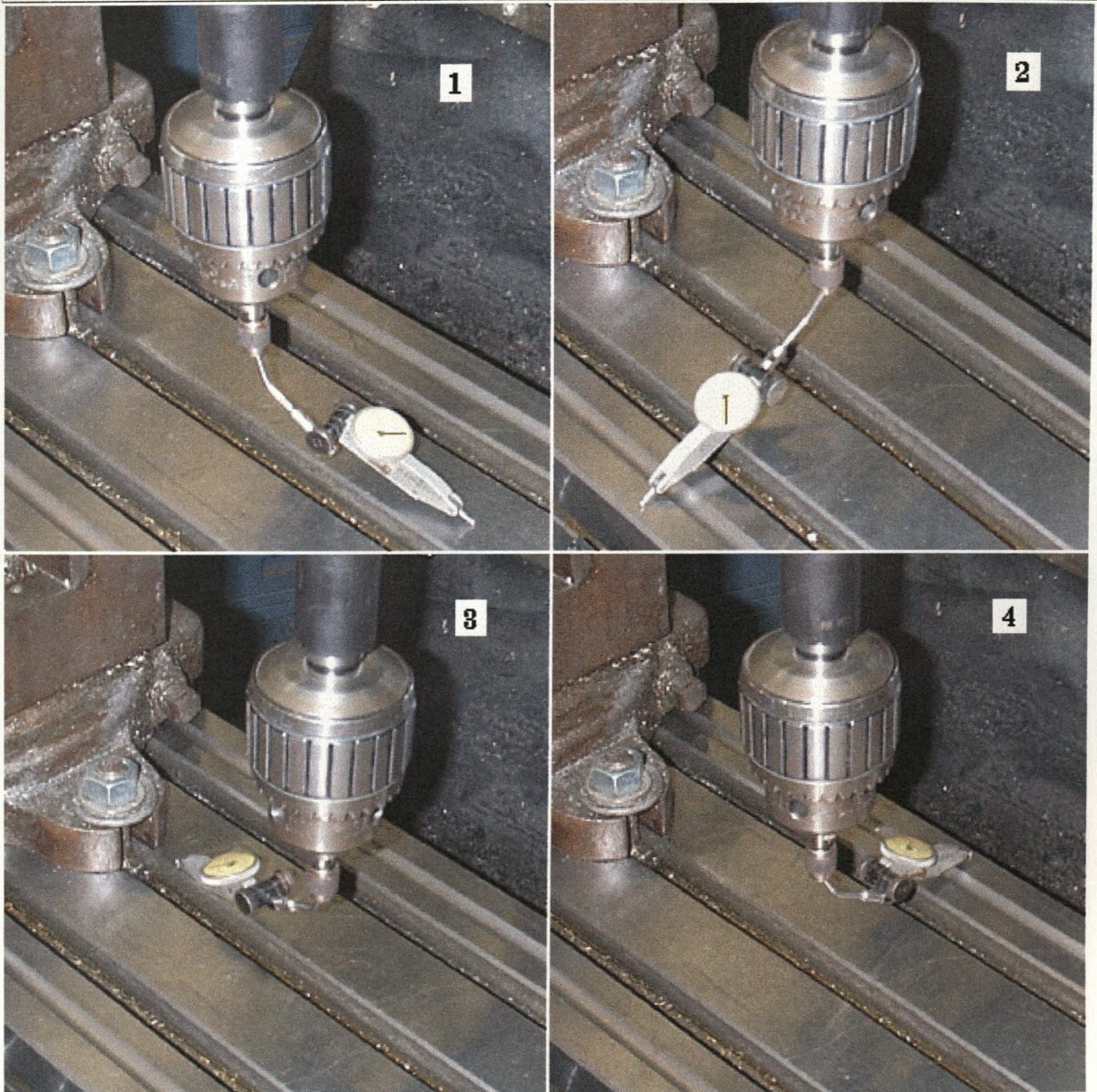

In order to align the head of the milling machine perpendicular to the table surface, a center finder set with a finger indicator can be used. The following instructions and the illustration above show how to do this.

1. Put the spindle gear drive in the neutral position.
2. Secure the universal ball chuck in the drill chuck.
3. Secure the indicator holder in the ball chuck.
4. Attach the finger indicator to the holder.

5. Line the spindle up over the middle of the table surface.
6. Extend the indicator and holder so that the maximum sweep can be obtained.
7. Raise the knee so that the indicator touches the table surface, then lock the knee to the column.
8. Rotate the spindle by hand while watching the needle on the indicator.
9. If the indicator reading is different from side-to-side, loosen the four bolts on the front of the head and use the worm adjustment to rotate the head to improve the alignment.
10. If the indicator reading is different from front-to-back, loosen the bolts that anchor the head to the overarm and use the worm adjustment to rotate the head to improve the alignment.
11. When the dial indicator reads the same in all four positions, the head is properly aligned.

NOTE: Double check the alignment after all the bolts have been retightened to ensure that no change in alignment has occurred.

· Milling Machine Vise ·

What is a milling machine vise?

A milling machine vise is a heavy-duty cast iron or steel vise consisting of a frame and fixed jaw, a moveable jaw, and a heavy ACME type screw and handle used to tighten the moveable jaw. It is used primarily to secure rectangular parts for milling. Most milling machine vises have slots in the bottom to enable keys to be used to line the vise up with a table slot. Replaceable jaws and swiveling capability are also common features.

It is a common procedure to line up the fixed jaw of a milling machine vise parallel with one of the table axes. The following illustrations and text describe this procedure.

Lining up a milling machine vise.



The easiest way to line up the fixed jaw of a milling machine vise with one of the table axes is to use a center finder set with a finger indicator.

1. Turn the power off and put the machine in low gear so that the spindle is hard to rotate.

2. Insert the universal ball chuck in the spindle and tighten the drill chuck.

3. Insert the indicator holder into the ball chuck and tighten the ball chuck as tightly as possible by hand.

4. Start by touching the finger indicator to one end of the jaw.

5. Move the proper axis handwheel to traverse the vise jaw past the indicator. (If the deviation is very bad, the indicator may run out of travel before reaching the opposite end of the jaw.)

6. Loosen the appropriate clamps to allow the vise to be rotated and carefully tap the vise with a soft hammer to improve the alignment. When the indicator does not change its reading from end-to-end, the vise is lined up.

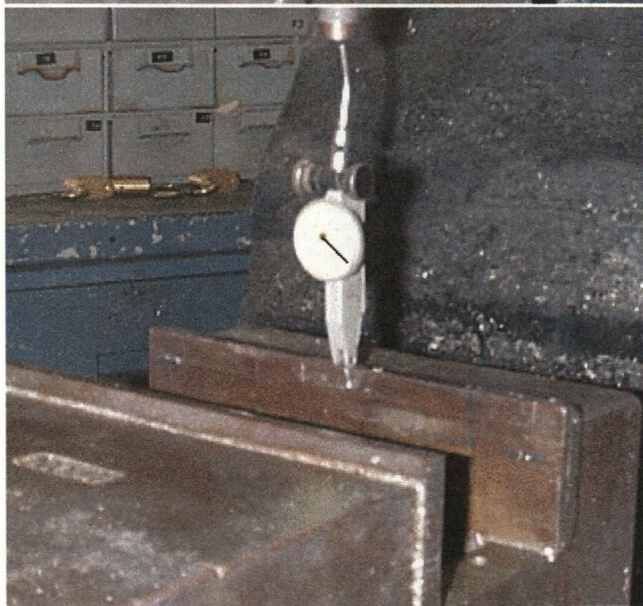

NOTE: Double check the vise after the clamps are retightened to ensure that no change in alignment has occurred.

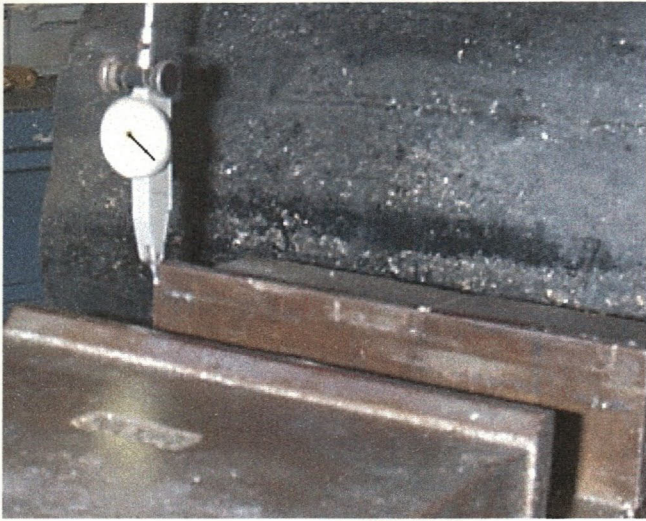

FLY CUTTING



DRILLING & REAMING

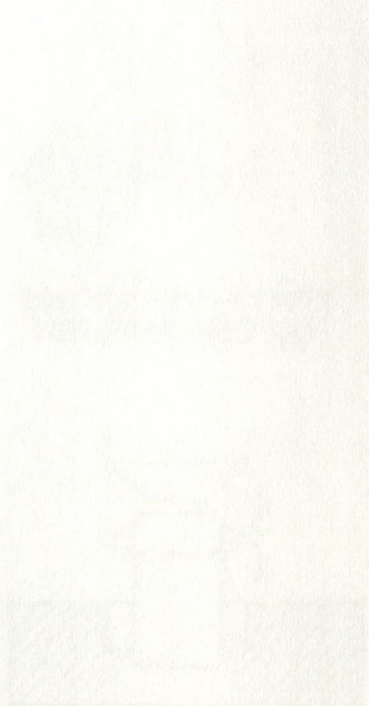

TURNING

· Vertical Milling Machine Operations ·

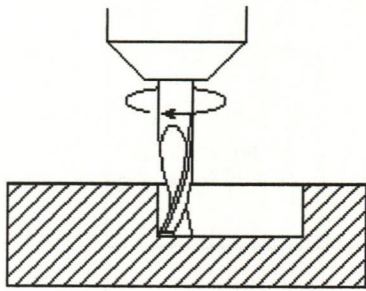

END MILLING OF SLOT

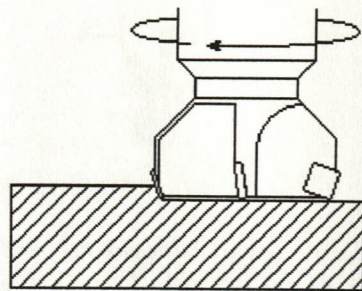

SLAB MILLING

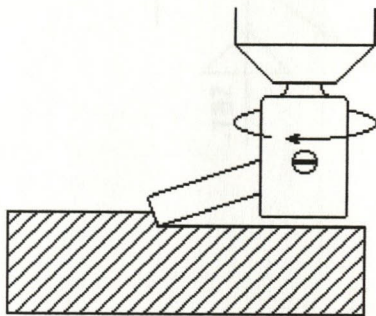

FLY CUTTING

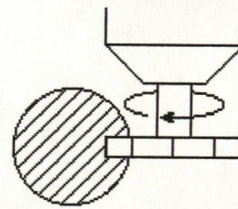

**SAW CUTTING OF SLOT
FOR WOODRUFF KEY**

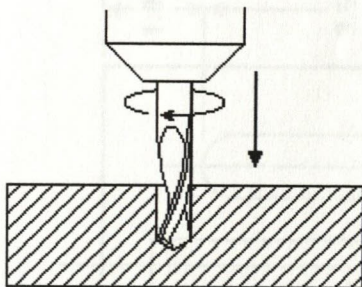

DRILLING & REAMING

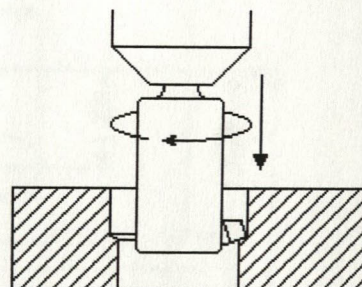

BORING

Angle Plates for Milling Machine

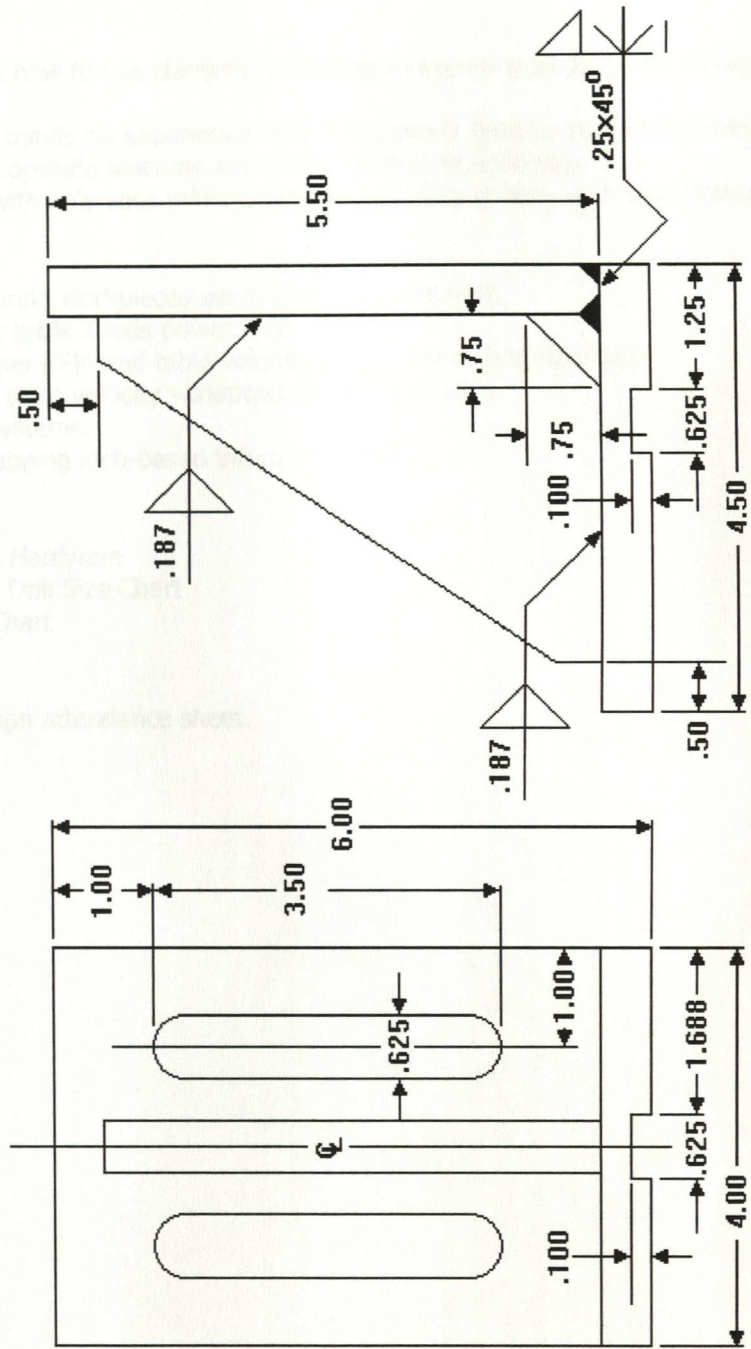

Machinist's Training - Lesson Plan

Session: Lexan #4/ CPP #4 & #5

Objectives

Have students learn how to use clamping hardware to secure workpieces to milling machine table.

Have students gain hands-on experience with using power feed to perform a milling operation.

Have every student operate machine and make various adjustments.

Acquaint students with reference information on drill and tap sizes and classification systems.

Topics

Setting up and securing workpieces using clamping hardware.

Adjusting and using table X-axis power feed.

Calculating the proper RPM and table velocity for an end-milling operation.

Effects of RPM and table velocity variations on chip and tool.

Drill classification systems.

Drill selection for tapping inch-based internal threads

Handouts

4.4 Basic Clamping Hardware

Number and Letter Drill Size Chart

Tap Drill Selector Chart

Comments

Be sure students sign attendance sheet.

Figure 4-12 Proper Workpiece Clamping

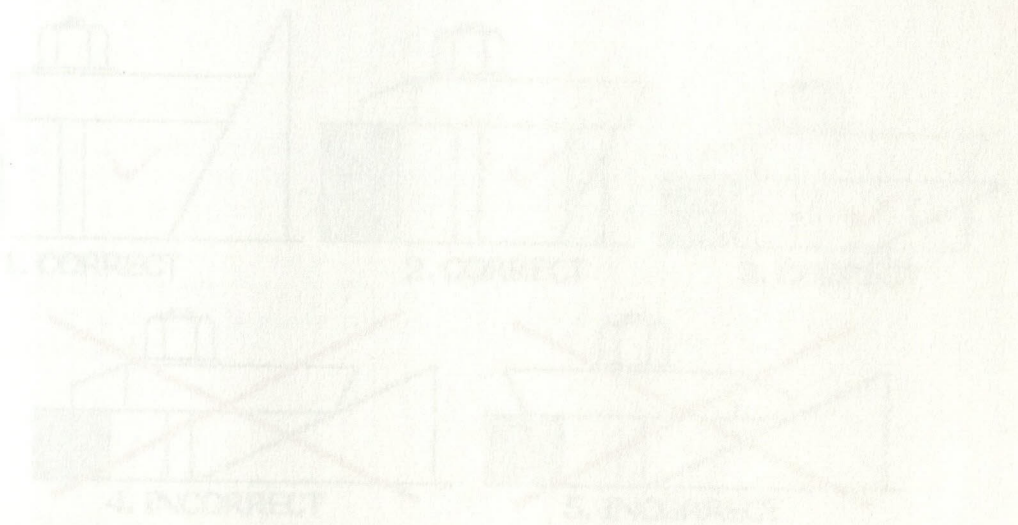

This figure provides a visual means of appraising the correct clamping arrangement of fixtures. The clamping force on the head of the clamp clamp and the angled face of the clamp should work together to secure the way. When used correctly (examples 1, 2, 4 & 5), the clamping force provided by the clamp arrangement is resisted through all the teeth in contact. When used improperly (examples 3 & 5), the clamping force is exerted on one tooth, which can chip or break off the tooth.

Figure 4-13 Proper Height Adjustment of Clamps

· 4.4. Basic Clamping Hardware ·

Illustration #1: Basic Clamping Hardware

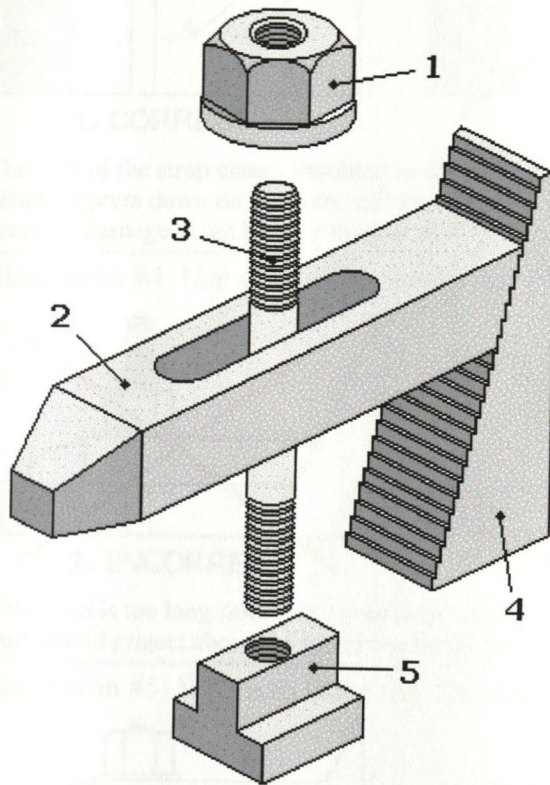

The basic hardware used to clamp workpieces and fixturing to the milling machine table is shown in Illustration #1. These components include:

1. Flanged nuts
2. Strap clamps
3. Threaded studs
4. Step blocks
5. T-nuts

The T-nuts slide into the T-shaped slots in the milling machine's table. A stud of the proper length is threaded into the T-nut. A clamp is placed over the stud, with the toe of the clamp resting on the top of the workpiece and the heel resting on a solid support such as a step block. Flat washers (not shown) can be placed over the stud before the flange nut is tightened in place.

This hardware can be obtained as individual pieces or as a set consisting of a number of studs and strap clamps of different lengths, pairs of step blocks in several different sizes, and a quantity of T-nuts and flanged studs.

Illustration #2: Proper Use of Step Blocks

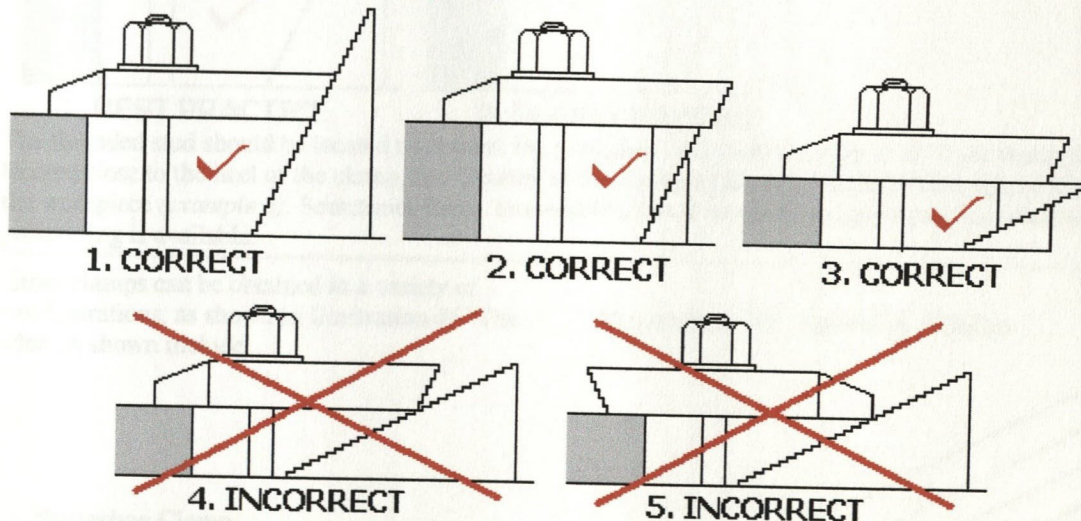

The step blocks provide a versatile means of supporting the heel of a strap clamp over a range of heights. The interlocking teeth on the heel of the strap clamp and the angled face of the step blocks will only fit together properly one way. When used correctly (*examples 1, 2, & 3*), the downward force exerted by the strap clamp is evenly distributed through all the teeth in contact. When used incorrectly (*examples 4 & 5*), the entire load is exerted on one tooth, which can chip or break off the tooth.

Illustration #3: Proper Height Adjustment of Clamp

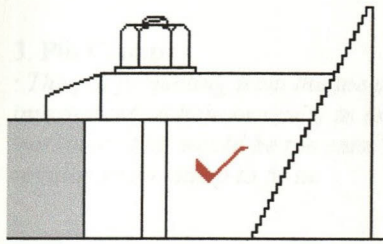

1. CORRECT

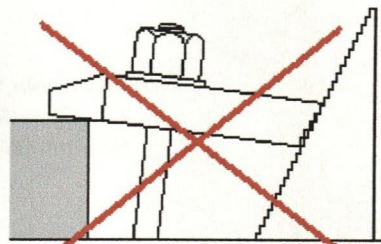

2. INCORRECT

The heel of the strap clamp should be at or above the height of the toe (*example 1*). This allows the toe of the clamp to press down on the body, not the edge (*example 2*), of the workpiece, preventing damage. It also prevents damage to the body or threads of the studs.

Illustration #4: Use of Washers Under the Flange Nut

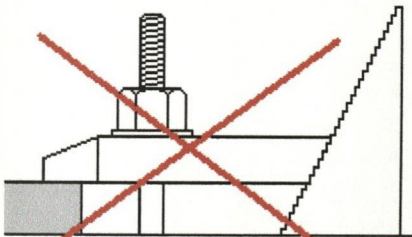

1. INCORRECT

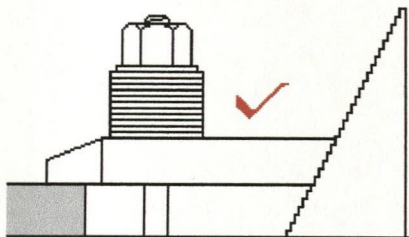

2. CORRECT

If the stud is too long (*example 1*), washers can be placed under the flange nut. No more than one thread of the stud should project above the top of the flange nut (*example 2*).

Illustration #5: Where to Place the Threaded Stud

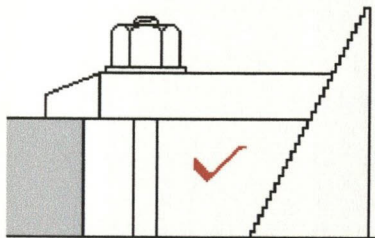

1. BEST PRACTICE

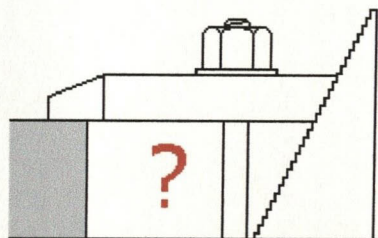

2. POOR PRACTICE

The threaded stud should be located as close to the workpiece as possible (*example 1*). If the threaded stud is located close to the heel of the clamp, the majority of the clamping force is exerted on the step block instead of the workpiece (*example 2*). Sometimes this is unavoidable, but it is considered poor practice whenever better positioning is available.

Strap clamps can be obtained in a variety of configurations, as shown in Illustration #6. The clamps shown include:

1. Horseshoe Clamp

- Often used on larger machines, these are usually forged from square stock.

2. Gooseneck Clamp

- Used to allow the top of the flange nut to be lower than the top of the clamp, which permits the machine head to get closer to the top of the workpiece.

Illustration #6: Specialty Clamps

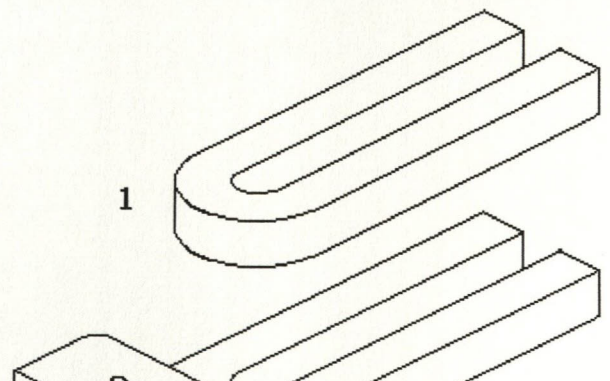

3. Pin Clamp

· The pin projecting from the toe of the clamp can be inserted into a hole or cavity in the side of the workpiece that would be too small for the toe of a regular strap clamp to fit in.

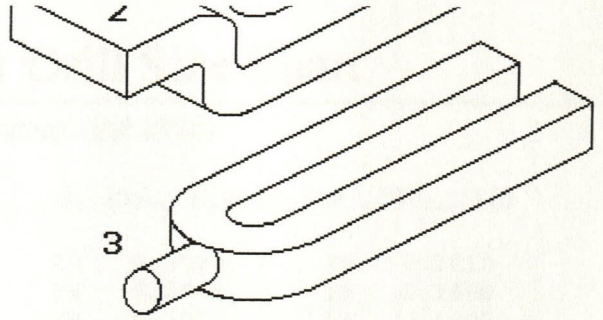

· Number & Letter Drill Size Chart ·

Number (Wire Gauge) Size Drills

#	DIA. (in)	#	DIA. (in)	#	DIA. (in)	#	DIA. (in)
80	0.0135	60	0.0400	40	0.0980	20	0.1610
79	0.0145	59	0.0410	39	0.0995	19	0.1660
78	0.0160	58	0.0420	38	0.1015	18	0.1695
77	0.0180	57	0.0430	37	0.1040	17	0.1730
76	0.0200	56	0.0465	36	0.1065	16	0.1770
75	0.0210	55	0.0520	35	0.1100	15	0.1800
74	0.0225	54	0.0550	34	0.1110	14	0.1820
73	0.0240	53	0.0595	33	0.1130	13	0.1850
72	0.0250	52	0.0635	32	0.1160	12	0.1890
71	0.0260	51	0.0670	31	0.1200	11	0.1910
70	0.0280	50	0.0700	30	0.1285	10	0.1935
69	0.0292	49	0.0730	29	0.1360	9	0.1960
68	0.0310	48	0.0760	28	0.1405	8	0.1990
67	0.0320	47	0.0785	27	0.1440	7	0.2010
66	0.0330	46	0.0810	26	0.1470	6	0.2040
65	0.0350	45	0.0820	25	0.1495	5	0.2055
64	0.0360	44	0.0860	24	0.1520	4	0.2090
63	0.0370	43	0.0890	23	0.1540	3	0.2130
62	0.0380	42	0.0935	22	0.1570	2	0.2210
61	0.0390	41	0.0960	21	0.1590	1	0.2280

Letter Size Drills

LETTER	DIA. (in)	LETTER	DIA. (in)
A	0.2340	N	0.3020
B	0.2380	O	0.3160
C	0.2420	P	0.3230
D	0.2460	Q	0.3320
E	0.2500	R	0.3390
F	0.2570	S	0.3480
G	0.2610	T	0.3580
H	0.2660	U	0.3680
I	0.2720	V	0.3770
J	0.2770	W	0.3860
K	0.2810	X	0.3970
L	0.2900	Y	0.4040
M	0.2950	Z	0.4130

· Tap Drill Selector Chart ·

UN Thread Series

<u>TAP SIZE</u>	<u>DRILL SIZE</u>	<u>DIA (in)</u>	<u>TAP SIZE</u>	<u>DRILL SIZE</u>	<u>DIA (in)</u>
0-80	3/64	0.0469	7/16-14	U	0.3680
1-64	#53	0.0595	7/16-20	25/64	0.3906
1-72	#53	0.0595	1/2-13	27/64	0.4219
2-56	#50	0.0700	1/2-20	29/64	0.4531
2-64	#50	0.0700	9/16-12	31/64	0.4844
3-48	#47	0.0785	9/16-18	33/64	0.5156
3-56	#45	0.0820	5/8-11	17/32	0.5312
4-40	#43	0.0890	5/8-18	37/64	0.5781
4-48	#42	0.0935	3/4-10	21/32	0.6562
5-40	#38	0.1015	3/4-16	11/16	0.6875
5-44	#37	0.1040	7/8-9	49/64	0.7656
6-32	#36	0.1065	7/8-14	13/16	0.8125
6-40	#33	0.1130	1-8	7/8	0.8750
8-32	#29	0.1360	1-12	59/64	0.9219
8-36	#29	0.1360	1 1/8-7	63/64	0.9844
10-24	#25	0.1495	1 1/8-12	1-3/64	1.0469
10-32	#21	0.1590	1 1/4-7	1-7/64	1.1094
12-24	#16	0.1770	1 1/4-12	1-11/64	1.1719
12-28	#14	0.1820	1 3/8-6	1-7/32	1.2188
1/4-20	#7	0.2010	1 3/8-12	1-19/64	1.2969
1/4-28	#3	0.2130	1 1/2-6	1-11/32	1.3438
5/16-18	F	0.2570	1 1/2-12	1-27/64	1.4219
5/16-24	I	0.2720			
3/8-16	5/16	0.3125			
3/8-24	Q	0.3320			

Machinist's Training - Lesson Plan

Session: Lexan #5/ CPP #6

Objectives

Have students learn how to use clamping hardware to secure workpieces to milling machine table.

Have students gain hands-on experience with using power feed to perform a milling operation.

Have every student operate machine and make various adjustments.

Acquaint students with reference information on the AISI/SAE coding system for alloy, tool, and stainless steels.

Topics

Setting up and securing workpieces using clamping hardware.

Adjusting and using table X-axis power feed.

Calculating the proper RPM and table velocity for an end-milling operation.

AISI/SAE alloy steel classification system

AISI/SAE tool steel classification system

AISI/SAE stainless steel classification system

Handouts

1.1 AISI/SAE Wrought Steel Code

1.2. AISI/SAE Tool Steel Code

1.3. AISI/SAE Stainless Steel Code

Comments

Be sure students sign attendance sheet.

· 1.1 AISI/SAE Wrought Steel Code ·

The AISI/SAE steel coding system for wrought steels consists of a four (or sometime five) digit number and several supplementary letters to specify the major alloying element(s), the carbon content, the method of manufacture, and whether lead has been added for machinability.

The two lefthand digits represent the **alloy category**.

The two (or three) righthand digits represent the **carbon content in 1/100%**. For example, 1018 steel has a carbon content of 18/100%, or .18%.

The method of manufacture (refining) is specified by a letter prefix, with **B = Bessemer** process refining, **C = Open Hearth** refining, and **E = Electric Arc** refining.

If lead has been added to promote machinability, the letter **L** is placed between the first two and last two digits, as in 12L14.

<u>Designation</u>	<u>Composition</u>
10XX.....	Plain carbon steels with no significant alloying additions
11XX.....	Free machining resulfurized plain carbon steel, originally made by the Bessemer refining process
12XX.....	Similar to 11XX, but made by the Open Hearth process
13XX.....	Manganese steels
20XX.....	Nickel steels
23XX	
25XX	
31XX.....	Nickel-chromium steels
40XX.....	Molybdenum steels
41XX.....	Chromium-molybdenum steels
43XX.....	Nickel-chromium-molybdenum steels
46XX.....	Nickel-molybdenum steels
48XX	
50XX.....	Chromium steels
51XX	
52XX	
61XX.....	Chromium-vanadium steels
86XX.....	Nickel-chromium-molybdenum steels, but with lower alloy content than the 43XX series
92XX.....	Silicon steels

· 1.2 AISI/SAE Tool Steel Code ·

Tool steels are formulated to satisfy specific industrial needs, thus their alloy makeup varies widely. Instead of classifying these steels by their alloy content, they are classified by their intended use. The AISI/SAE coding system for tool steels consists of a letter prefix that corresponds to the intended use, followed by a number indicating the chronological order of adoption as a recognized alloy grade.

Category Designation	Letter Symbol	Group Designation
High Speed Tool Steels	M T	Molybdenum types Tungsten types
Hot Work Tool Steels	H1-H19 H20-H39 H40-H59	Chromium types Tungsten types Molybdenum types
Cold Work Tool Steels	D A O W	High carbon, high chromium types Medium alloy air-hardening types Oil-hardening types Water-hardening types
Shock Resisting Tool Steels	S	(compositions vary)
Mold Steels	P	(compositions vary)
Special Purpose Tool Steels	L F	Low alloy types Carbon-tungsten types

· 1.3 AISI/SAE Stainless Steel Code ·

Stainless steels are defined as steels with a chromium content greater than 14% that show passivation (lack of surface oxidation) in an oxidizing environment. The microstructure of stainless steel can be ferritic, martensitic, austenitic, a combination of these, or a more complex structure formed by **Precipitation Hardening (PH)**.

The stainless steel coding system consists of a three digit number. The first number indicates the material grade; the other two numbers serve only to designate a specific alloy within that grade.

The austenitic and ferritic grades **cannot** be hardened by heating and quenching; only the martensitic grades are hardenable by standard heat-treatment methods. The PH grades are hardenable by a special type of heat-treatment known as **artificial aging**.

Note that the austenitic grades are not magnetic; the ferritic and martensitic grades are magnetic at room temperature. The PH grades may or may not be magnetic, depending on the underlying microstructure.

The high chromium content in stainless steel makes most grades difficult to machine. **Free machining** grades of stainless steel are made by adding sulfur or selenium; if selenium is used the chemical symbol Se is added as a suffix.

Although most grades of stainless steel can be welded, the high chromium content can cause **carbide formation** and the consequent cracking, leaking, and loss of strength in welded joints. Extremely low carbon weldable grades of stainless steel are indicated by an **L** added as a suffix, as in 304L.

<i>Alloy</i>	
<i>Designation</i>	<i>Composition/Microstructure</i>
2XX.....	Chromium-nickel-manganese, austenitic
3XX.....	Chromium-nickel, austenitic
4XX.....	Chromium, ferritic (grades 405, 430, 442, 446) Chromium, martensitic (all other 4XX grades)
5XX.....	Low chromium, martensitic
PHXX-YY.....	Precipitation hardening grades, where XX stands for the percent of chromium and YY stands for the percent of nickel in the alloy. An example would be PH18-8 which has approximately 18% Cr and 8% Ni.

Machinist's Training - Lesson Plan

Session: Lexan #6 & #7/ CPP #7 & #8

Objectives

Familiarize students with the features and controls of the engine lathe.
Familiarize students with specific safety problems relating to the engine lathe.
Familiarize students with the available tooling for the engine lathe.
Familiarize students with the proper way to set up tools on the engine lathe.
Familiarize students with the proper way to secure workpieces in the three-jaw chuck.
Give the students experience in operating the controls of the engine lathe.

Topics

Machine features and controls
Engine lathe safety
Tooling for turning and boring
Use of three-jaw chuck
Machine operation - set RPM and feed, use apron controls

Handouts

1. Parts of the Engine Lathe*
1.1. Headstock*
1.3. Carriage & Cross Slide*
3.1. Specific Lathe Safety Areas*
Engine Lathe Machining Operations

*Use handouts appropriate to each functional area

Comments

Be sure students sign attendance sheet.

· 1. Parts of the Engine Lathe ·

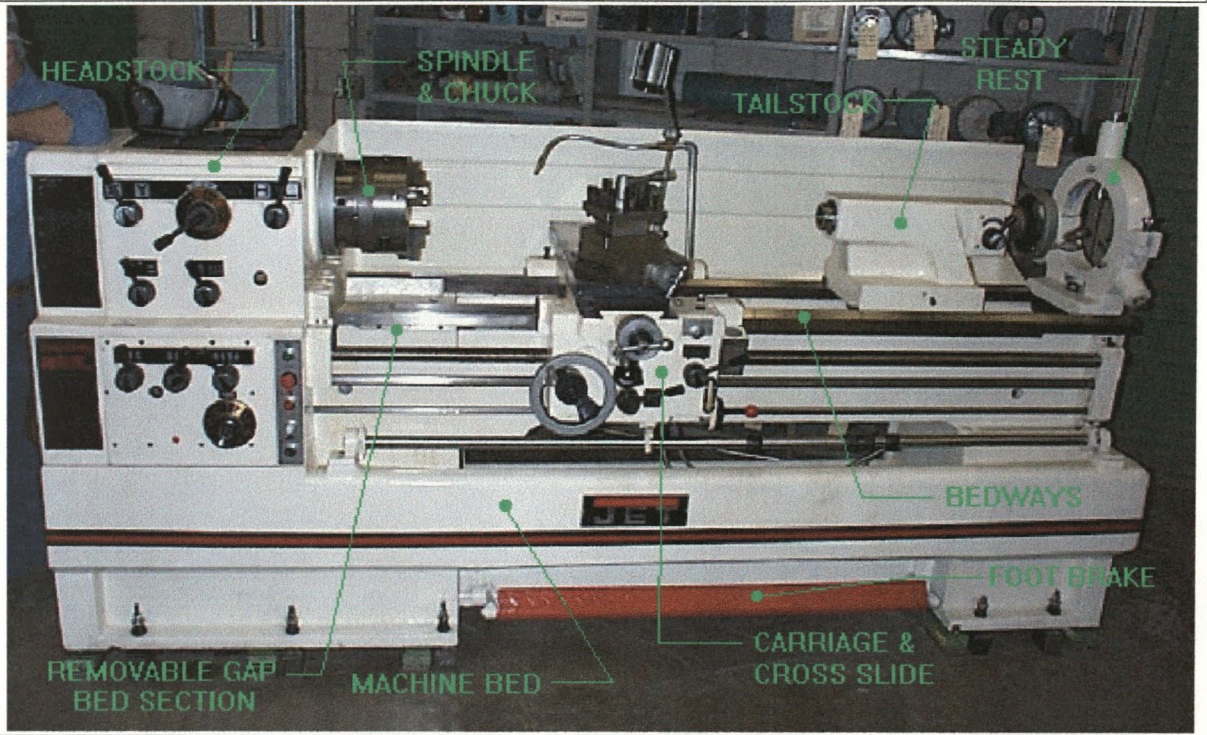

For more details, click on any of the parts of the lathe in the picture above.

· 1.1. Headstock ·

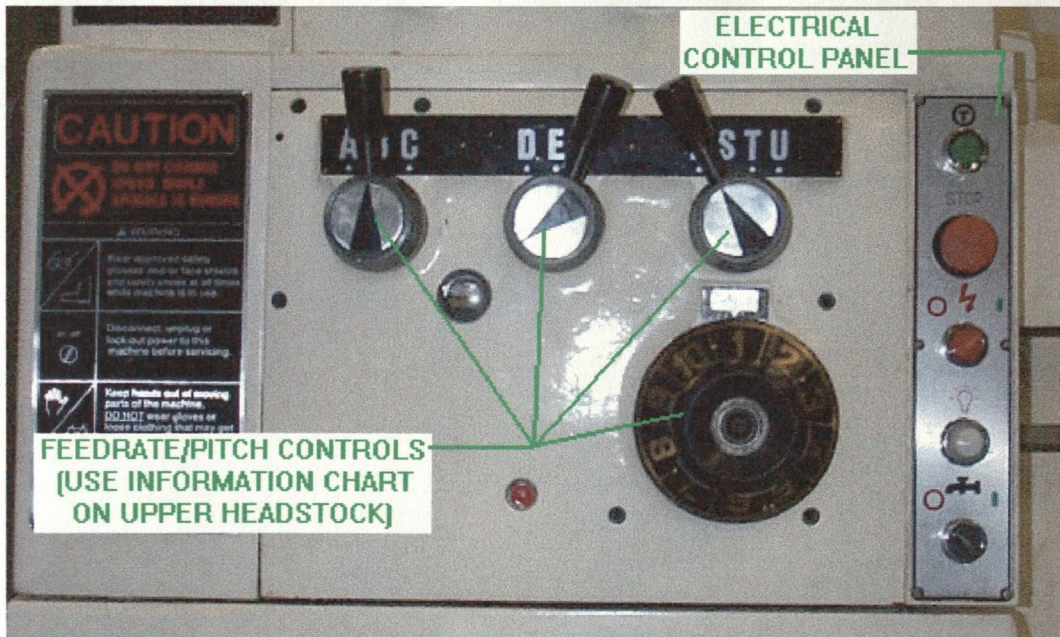
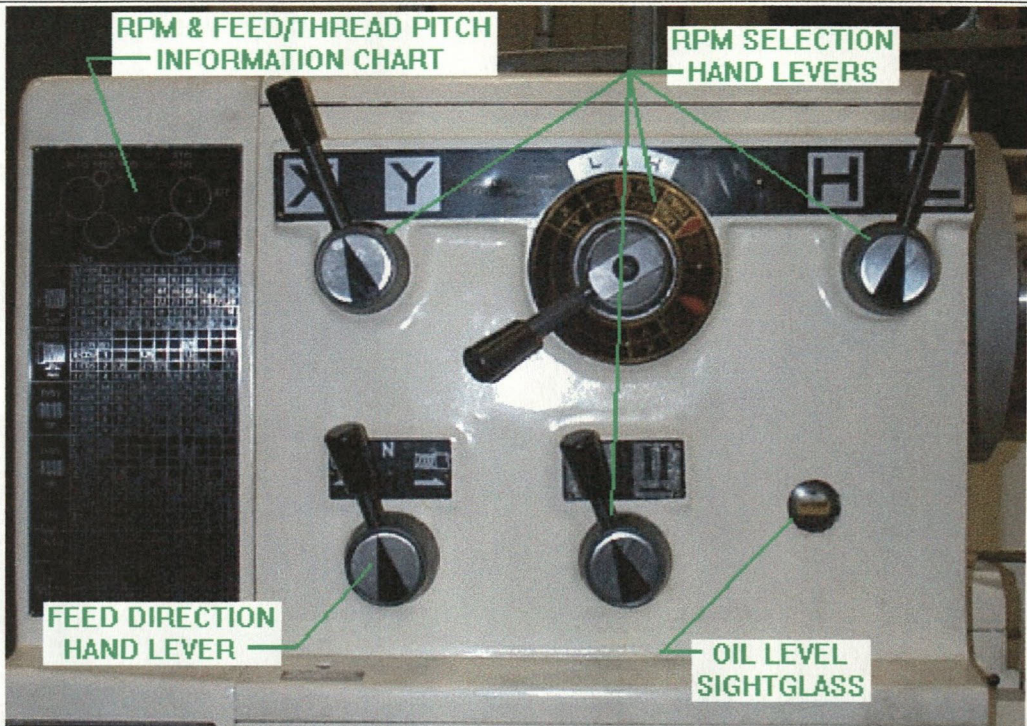

· 1.3. Carriage & Cross Slide ·

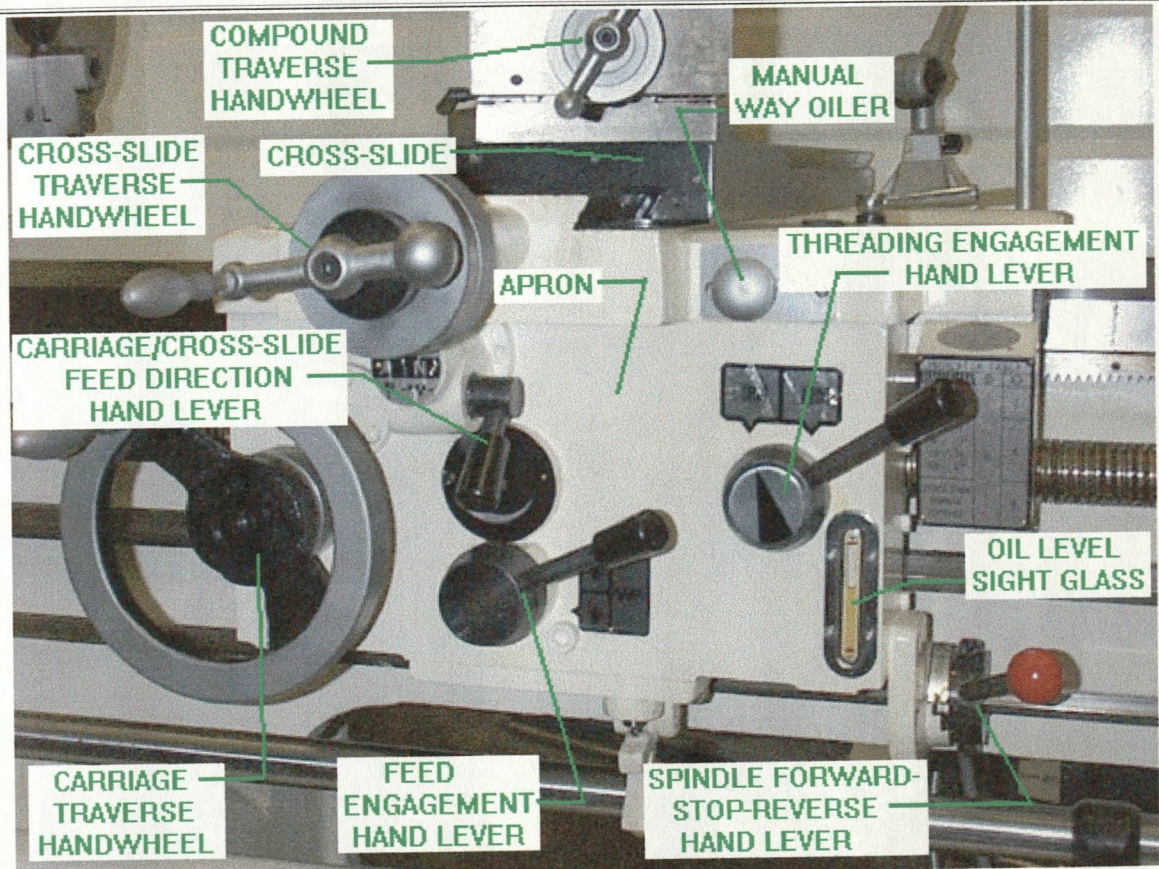

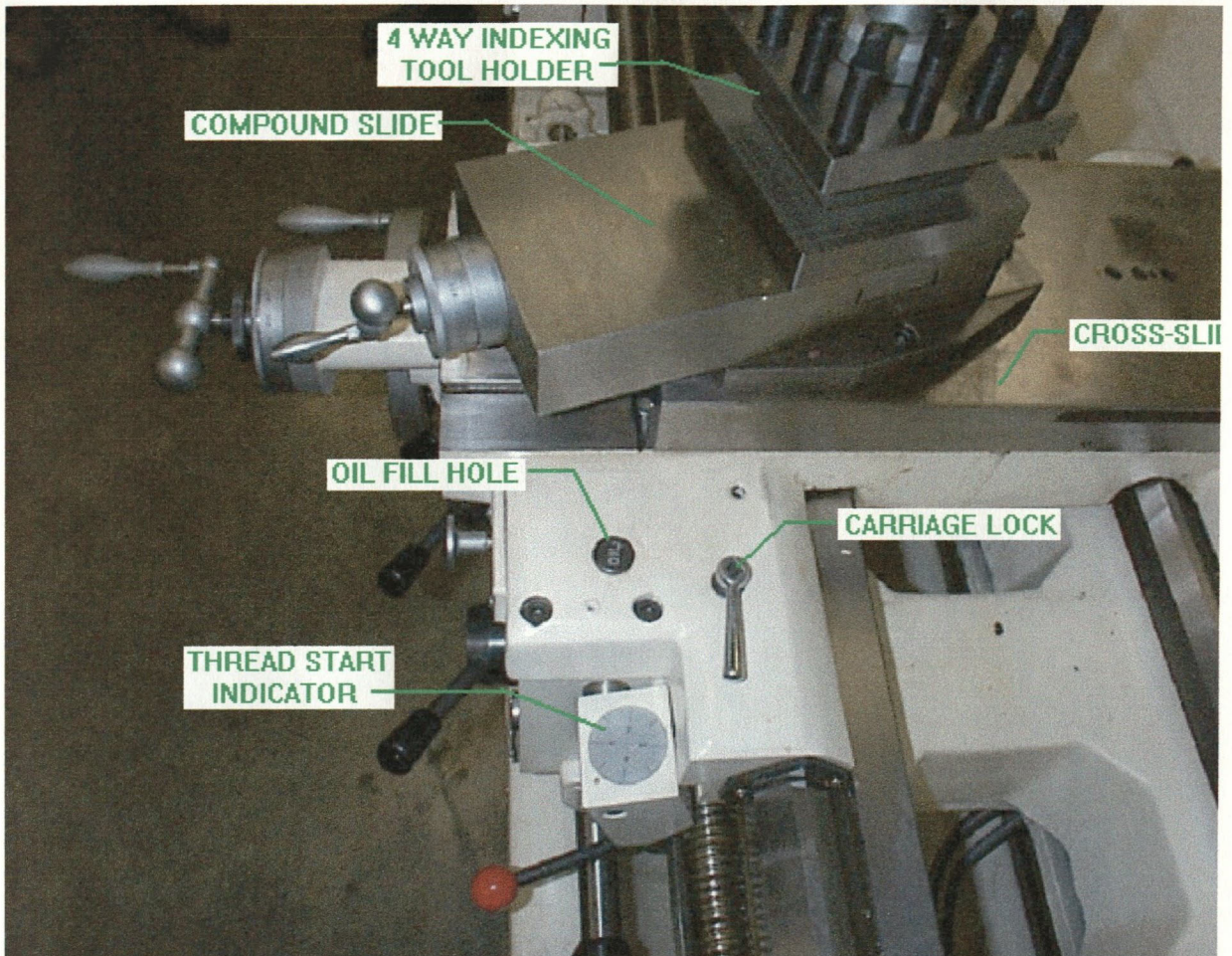

1. The work around the work should be...
2. The footbrake should be engaged...
3. The top of the headstock can be used for holding small tools, but it should not be used for holding tools that will fall off and fall into the rotating work.
4. The use of compressed air should be avoided to clean the workpiece and the operator and any bystanders. If the compressed air must be used, the pressure should be limited to 30 psig or less.
5. Before starting the spindle, be sure the part is properly secured and that the chuck wrench is removed from the chuck.
6. Lower the check guard only as far as needed to allow the work to rotate.
7. Wearing a full-face shield is recommended when turning thin rods at high speeds.
8. Be sure that the chuck is firmly attached to the spindle nose.

3.1 Specific Lathe Safety Areas

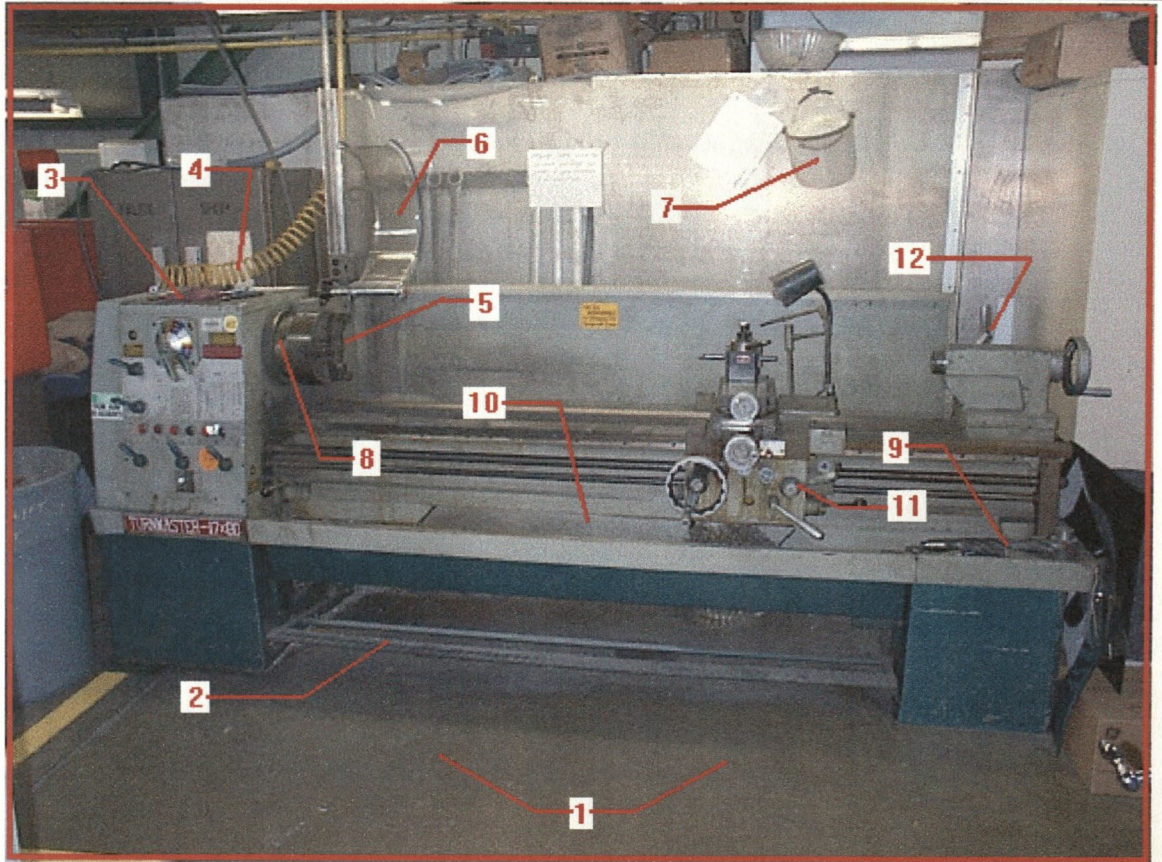

1. The area around the lathe should be kept free of debris to prevent tripping injuries.
2. The footbrake should be kept adjusted so that the spindle can be rapidly and safely stopped.
3. The top of the headstock can be safely used as a place to lay scales, micrometers, and other small tools, but it should not become cluttered. Round stock or any other item which might roll off and fall into the rotating chuck should not be stored here.
4. The use of compressed air should be limited to prevent damage to the lathe and injury to the operator and any bystanders. If the use of compressed air is necessary, the output pressure should be limited to 30 psig or less.
5. Before starting the spindle, be sure the part is properly secured in the chuck and that the chuck wrench is removed from the chuck.
6. Lower the chuck guard (shown in the raised position) before starting the spindle.
7. Wearing a full-face shield is recommended when turning brittle materials at high speeds.
8. Be sure that the chuck is firmly attached to the spindle nose.

9. Tools should not be stored anywhere that might limit the movement of the carriage.
10. The chip tray should be cleaned regularly, especially when long stringy chips that might become tangled in the chuck start to build up.
11. Know the difference between the threading engagement lever and the feed engagement lever! Since threading generally moves the carriage at a much faster rate than feeding, the operator may be caught unaware when the carriage "takes off" at high speed.
12. Make sure the tailstock is securely locked when drilling. Make sure the tailstock and tailstock quill are both locked when turning work between centers.

DRILLING

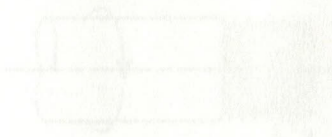

EXTERNAL
THREADING



PARTING
OR
CUTOFF



· Engine Lathe Machining Operations ·

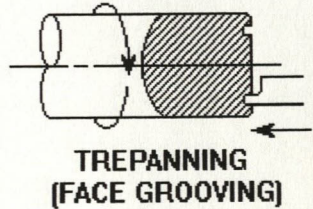
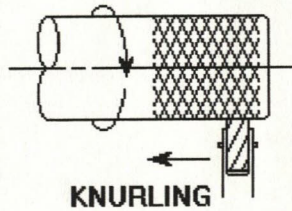
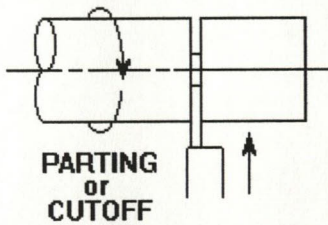
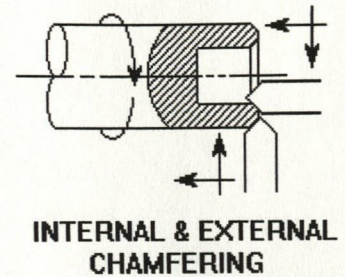
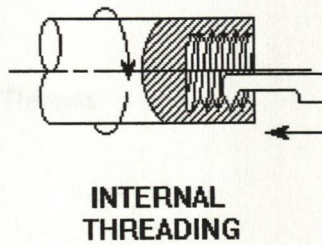
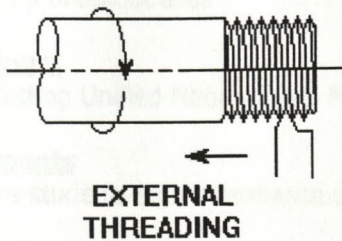
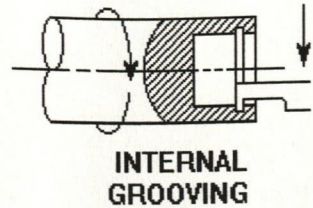
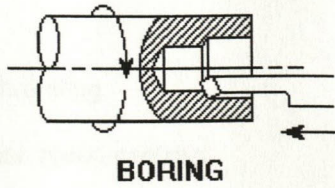
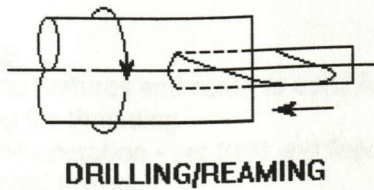
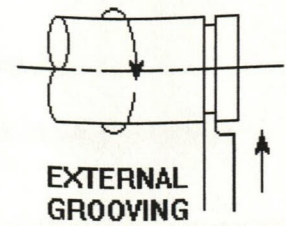
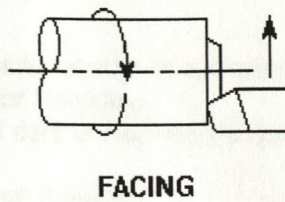
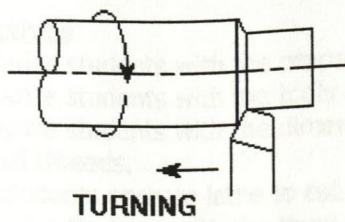

Machinist's Training - Lesson Plan

Session: Lexan #8 & #9/ CPP #9

Objectives

Familiarize students with the proper procedures used to cut external threads.

Familiarize students with the tools used for threading.

Familiarize students with the dimensional data in Machinery's Handbook relating to Unified National threads.

Have students operate lathe to cut external threads.

Familiarize students with the three ways to check an external thread to ascertain the correct size and pitch.

Topics

Machine features and controls used for threading

Tooling for threading

Machine operation - set RPM and feed, use apron controls

UN thread history

UN thread features

Cutting a breakout area

Handouts

7.1. Cutting Unified National and Metric Threads

Comments

Be sure students sign attendance sheet.

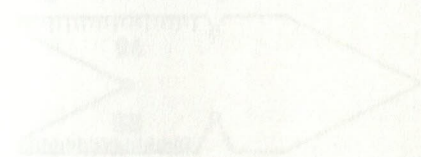

· 7.1. Cutting Unified National and Metric Threads ·

Cutting threads is an operation for which a lathe is ideally suited. The process is relatively simple, but requires great care on the part of the machinist. The step-by-step description given here is one way to perform this machining process.

The directions below apply to cutting right hand external threads and assume that the major (outside) diameter has been turned to size and that a suitable breakout area has been cut into the workpiece.

Illustration #1: Lathe Cross-Slide and Compound Slide Set Up for Threading

Step #1. Set the compound slide to the same angle as the trailing flank of the thread to be cut. For a Unified National thread this angle is 30° , as shown in Illustration #1. (NOTE: This illustration is for cutting **right hand external** or **left hand internal** threads. For cutting **left hand external** or **right hand internal** threads, the compound should be set to 30° in the opposite direction.) Use the protractor markings on the compound slide for this.

Step #2. Align the cutting tool using a threading tool gauge such as the one shown in Illustration #2. One edge of the threading tool gauge should be held up against any cylindrical surface of the workpiece. The tool holder should first be adjusted to the proper center height and then rotated left or right to visually align the cutting edges of the tool with one of the V-shaped slots of the gauge.

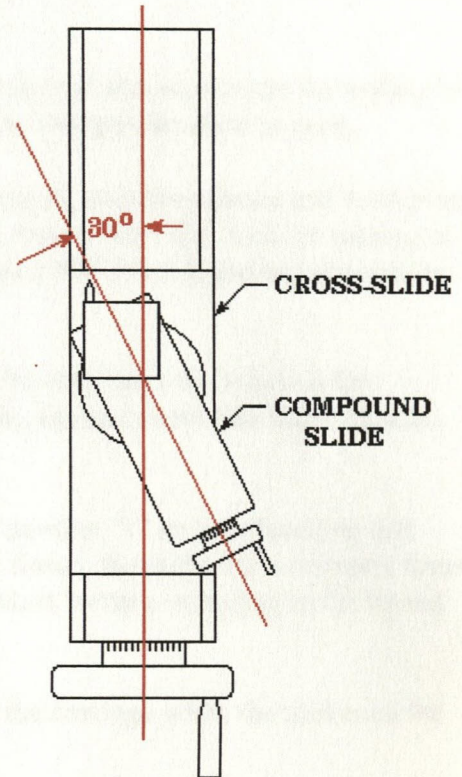
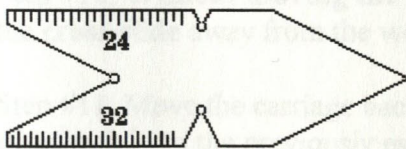

Illustration #2: Threading Tool Grinding and Alignment Gauge



Step #3. Use the headstock gear change levers to obtain the proper pitch for the thread to be cut. This is usually marked on a plate attached to the lathe headstock. Double check the change gears inside the headstock cover if you are unsure about which change gear ratio has been set up.

Step #4. Check to be sure the threading dial (normally found on the right hand side of the carriage, as shown in Illustration #3) is engaging the lead screw. (NOTE: To prevent excessive wear to the lead screw, it is considered good practice to disengage the threading dial from the lead screw when performing other lathe operations.)

Illustration #3: Threading Dial

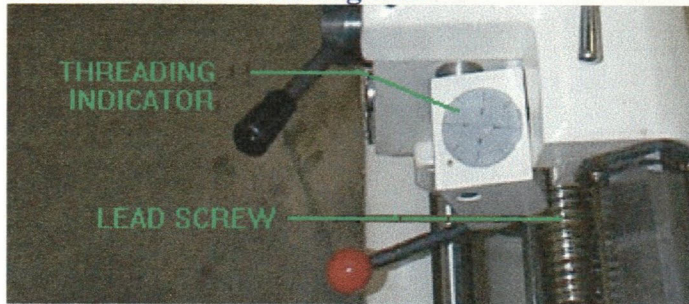

Step #5. Screw in the cross-slide until the tip of the cutting tool almost touches the surface to be threaded. **Set the dial on both the cross-slide and the compound slide to zero.**

Step #6. After making sure the workpiece is properly secured, start the spindle and workpiece rotating. The RPM should be set to a value considerably slower than that used for turning or facing. The surface finish, which can be poor if too low an RPM is used, can be improved by using an appropriate cutting fluid.

Step #7. With the tool at the right hand end of thread to be cut, move the tool in a few thousandths of an inch by screwing in the compound slide. **Do not move the cross-slide in, leave it set to zero.**

Step #8. Engage the thread engagement lever just as the number "1" on the threading dial comes around into alignment with the index mark on the frame. Be prepared for a much faster carriage traverse velocity than is normally encountered when turning or boring as the thread helix is generated.

Step #9. Disengage the thread engagement lever to stop the carriage when the tool exits the end of the cut and enters into the breakout area.

Step #10. **Without moving the compound slide**, withdraw the tool from the cut by moving the **cross-slide** away from the workpiece.

Step #11. Move the carriage back to the right hand end of the workpiece and screw the **cross-slide** back in to the previously established zero.

Step #12. Move the tool in toward the workpiece by screwing in the compound slide a few more thousandths of an inch.

Step #13. Repeat steps #8 through #12 until the thread is cut to size. Note that for some thread pitches, numbers on the thread dial other than "1" can also be used, but "1" will **always** work for **all** thread pitches.

Step #14. The thread can be checked by:

(a). using the three-wire method and a standard outside micrometer - see Machinery's Handbook for more information on how to do this;

(b). using a special thread-type micrometer.

(c). screwing on a nut - this is the least accurate method but is suitable for most maintenance work if care is taken to remove all burrs on the threads.

Machinist's Training - Lesson Plan

Session: #10

Objectives

Verify student's knowledge of shop math by giving written examination.

Verify student's ability to read an inch-based micrometer and vernier scale by giving a written examination.

Verify the student's ability to use reference materials by giving a written examination.

Verify student's knowledge of shop safety rules by giving a written examination.

Verify student's knowledge of various machine features and controls by having students point out, describe the function, and operate (where applicable) when given the name of the feature.

Verify student's ability to select and set up cutting tools to perform specific machine operations by giving a performance examination.

Verify the student's knowledge of how to use a center finder set, dial indicator, and finger indicator by oral examination.

Topics

Shop math

Measurement tools

Using reference materials

Shop safety

Machine features, controls, and operation

Indicators and center finder tools

Tooling

Handouts

Written examination (content to be decided)

Comments

Buy doughnuts for class!